



# INSTRUCT POWER ANALYZER 2.0

## User Manual





Document No. MA24114, Rev. 1.0

May 2024

## IMPORTANT SAFETY INFORMATION

### SYMBOLS AND TERMS

Read user instructions carefully and visually inspect the equipment to become familiar with the device before installing, operating, or maintaining it. The following messages may be used in this document to help ensure personal safety and efficient handling of equipment.

	<p><b>DANGER</b></p> <p>A hazardous situation which, if not avoided, will result in serious injury or death.</p>
	<p><b>WARNING</b></p> <p>A hazardous situation which, if not avoided, can result in serious injury or death, major loss of property, or catastrophic business risk.</p>
	<p><b>WARNING – ELECTRICAL SHOCK</b></p> <p>An electrical hazard which will result in personal injury if instructions are not followed.</p>
	<p><b>CAUTION</b></p> <p>A hazardous situation which, if not avoided, can result in minor or moderate injury, loss of property, or business risk.</p>

---

**Important** Non-urgent information that may impact the outcome of a process or procedure.

---

**Note** Non-urgent information that may be of interest to a user.

---

## CONTACT SENSIA

For technical support, please refer to <https://www.sensiaglobal.com/Technical-Support>.

For all other inquiries, please refer to <https://www.sensiaglobal.com/Customer-Care> or dial 1-866-773-6742.

## REVISION HISTORY

Revision	Description of Change	Issuer	Approver	Date
01	Release to production	R. Avila Reyes, K. Metzger	D. Kelly	May 31, 2024

---

## **PUBLISHER NOTES**

### **DISCLAIMER**

Whilst Sensia has taken every care in the preparation of this document, it cannot accept responsibility for printing errors or omissions and does not warrant that it is correct and comprehensive in every particular. Equipment supplied should always be operated by persons with an appropriate level of skill and training.

Sensia shall not be liable for incidental or consequential damages resulting from the furnishing, performance or use of this material.

Sensia pursues a policy of continuous improvement, and information given herein may be updated without notice. Further, this information is proprietary to Sensia, and must not be disclosed to any third party except as may be required to operate the equipment supplied in accordance with the purposes for which it was sold by the persons properly licensed to operate it.

### **COPYRIGHT NOTICE**

Copyright © 2024 SENSIA. All rights reserved. This work contains the confidential and proprietary trade secrets of Sensia and may not be copied or stored in an information retrieval system, transferred, used, distributed, translated or retransmitted in any form or by any means, electronic or mechanical, in whole or in part, without the express written permission of the copyright owner.

### **TRADEMARKS & SERVICE MARKS**

Sensia, the Sensia logotype, and other words or symbols used to identify the products and services described herein are either trademarks, trade names, or service marks of Sensia and its licensors or are the property of their respective owners. These marks may not be copied, imitated, or used, in whole or in part, without the express prior written permission of Sensia. In addition, covers, page headers, custom graphics, icons, and other design elements may be service marks, trademarks, and/or trade dress of Sensia and may not be copied, imitated, or used, in whole or in part, without the express prior written permission of Sensia.

### **WARRANTY**

Product warranty is specified in Sensia Terms and Conditions at the time of purchase.

## Table of Contents

<b>Section 1 : Introduction</b> .....	<b>7</b>
1.1 Application Overview .....	7
1.2 About this Document .....	8
1.3 Related Documents .....	9
<b>Section 2 : System Requirements</b> .....	<b>10</b>
2.1 Hardware Requirements.....	10
2.1.1 HCC2 Controller.....	10
2.1.2 PowerDAQ Module .....	12
2.1.3 Current Sensors .....	14
2.1.4 Installation Cables.....	15
2.2 Software Requirements .....	16
2.3 Data and Measurement Requirements .....	16
2.3.1 Motor Design Data .....	16
2.3.2 Inputs for Synchronous Acquisitions.....	18
2.3.3 Voltage and Current Measurement.....	18
2.4 Communication Requirements .....	18
2.4.1 Ethernet Communications.....	18
2.4.2 Serial Communication .....	18
2.4.3 Avalon Communications .....	19
<b>Section 3 : Theory of Operations</b> .....	<b>20</b>
3.1 High-Level Operations.....	20
3.1.1 Prognostic Health Monitoring .....	21
3.1.2 Optimization .....	21
3.1.3 Diagnostic and Post-Mortem Analysis .....	21
3.2 Power Analyzer 2.0 Outputs.....	21
<b>Section 4 : Field Installation</b> .....	<b>27</b>
4.1 Required Tools and Site Preparation .....	27
4.2 HCC2 Controller Cabinet.....	28
4.3 PowerDAQ and Current Sensors .....	30
4.3.1 Install Sensors.....	31
4.3.2 Complete PowerDAQ Connections.....	33
4.4 Internet Connectivity .....	36
<b>Section 5 : Commissioning</b> .....	<b>37</b>
5.1 Required Tools and Preparations.....	37
5.2 Power on the HCC2 Cabinet .....	37

---

5.3 Configure and Enable the PA2 Application .....	38
5.3.1 Log in to HCC2 Web UI (Unity Edge) .....	38
5.3.2 Configure the Power Analyzer 2.0 Application.....	39
5.4 Provision the HCC2 Controller .....	44
5.4.1 Pairing the Asset with the HCC2.....	46
5.5 Verify Avalon Connectivity.....	48
5.6 Start-Up .....	49
<b>Section 6 : Monitoring Data in Unity Edge .....</b>	<b>50</b>
6.1.1 Overview Dashboard.....	51
6.1.2 System Condition Monitoring .....	52
6.1.3 Harmonics .....	52
6.1.4 Voltage Current Power.....	54
<b>Section 7 : Monitoring Data via the Local HMI.....</b>	<b>56</b>
7.1 Navigating the HMI .....	56
7.1.1 Home Screen .....	56
7.1.2 Top Navigation Bar .....	58
7.1.3 Main Menu.....	58
7.1.4 Navigation Tabs .....	59
7.1.5 Data Presentation Options.....	59
7.1.6 Communications Failure .....	60
7.2 Operate Screens.....	60
7.3 Trends and Charts.....	64
<b>Section 8 : Monitoring Data in Avalon .....</b>	<b>67</b>
8.1 Lift Surveillance .....	67
8.1.1 General Overview.....	67
8.1.2 Waveforms (Raw Signals).....	67
8.1.3 Phasors .....	68
8.1.4 Live Data (Tag List).....	68
8.1.5 Trends (Templates).....	69
<b>Section 9 : Troubleshooting .....</b>	<b>70</b>
9.1 Mechanical/Installation Troubleshooting .....	70
9.1.1 Failure to Power on the PA2 Controller .....	70
9.1.2 Failure to Access Unity Edge User Interface via USB .....	70
9.1.3 PA2 Controller and Avalon Provisioning and Communication Issues .....	72
9.1.4 Parameter values in HMI or Unity Edge screens appear stagnant or frozen .....	74
9.2 Applications Troubleshooting .....	75

---

<b>Section 10 : Integrating the HCC2 and INSTRUCT Motor Controller via Modbus .....</b>	<b>76</b>
10.1 Preloaded Modbus Protocol Mappings .....	76
10.2 HCC2/Instruct Serial Communications Wiring .....	77
10.3 Configure INSTRUCT Motor Modbus RTU Server Settings .....	78
10.4 Configure HCC2 Controller Modbus RTU Client Settings.....	78
10.4.1 Verify the Modbus Integration .....	80
<b>Appendix A : HCC2/INSTRUCT Modbus Reference Guide .....</b>	<b>A-1</b>
<b>Appendix B : HCC2/PA2 Modbus Reference Guide.....</b>	<b>B-1</b>
<b>Appendix C : Wiring Diagrams .....</b>	<b>C-1</b>
<b>Appendix D : Mechanical Drawings .....</b>	<b>D-1</b>
<b>Appendix E : Tag Definitions (Monitoring and Charts) .....</b>	<b>E-1</b>
<b>Appendix F : Parts, Spares, Tools, and Supplies .....</b>	<b>F-1</b>

# Section 1: Introduction

## 1.1 APPLICATION OVERVIEW

The INSTRUCT™ Power Analyzer 2.0 (PA2) Application helps operators to maximize production by enabling power optimization, failure prevention, and prognostic health monitoring.

The PA2 uses surface measurement devices to infer downhole parameters and provides a calculation engine to monitor and process the high-speed motor electrical data while operating an Electrical Submersible Pump (ESP) for artificial lift.

The PA2 reads three-phase voltage and current measurements, which are obtained by a PowerDAQ module and transmitted to the Sensia QRATE™ Hyper Converged Controller (HCC2) to enable functions such as:

- Synchronous acquisitions of three-phase voltage and current measurements at a high-frequency rate
- Extraction of performance and diagnostic data for the complete system or for select components
- Power Quality Monitoring (PQM), system condition monitoring, independent backspin analysis, true shaft speed & torque modelling
- Detection and measurement of abnormalities using waveforms, phasors, and trends

The PA2 can integrate a variety of drives or transformers using the Sensia PowerDAQ module and the Sensia hyperconverged controller (HCC2).

The PA2 is configured in the Unity Edge interface for the HCC2 controller ([Figure 1.1](#)).

The PA2 displays measured and calculated data in the HCC2 Unity Edge interface, on a local HMI display ([Figure 1.2](#)), in a cloud-based Avalon software environment ([Figure 1.3](#)), or in a customer SCADA system<sup>1</sup> to support continuous field monitoring and analysis.

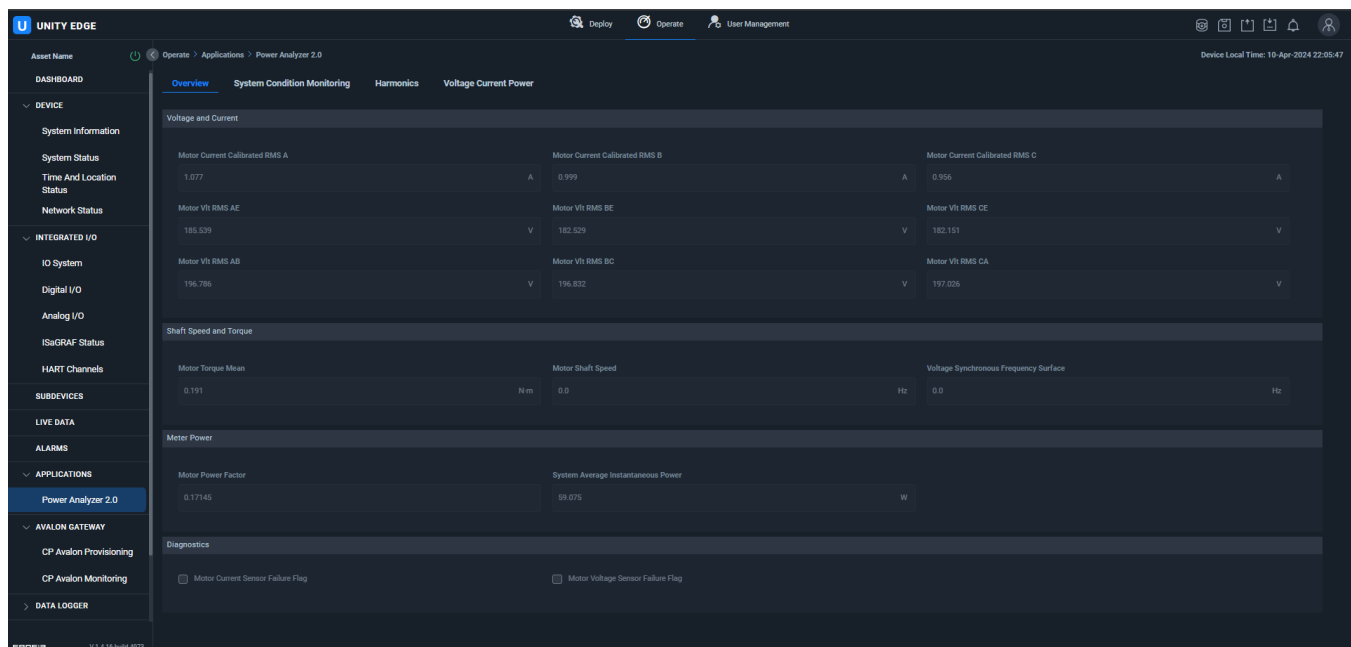

Figure 1.1—Unity Edge web interface for configuring and monitoring the PA2

<sup>1</sup> SCADA implementation support is available only for PA2 applications sold as part of a customized solution.

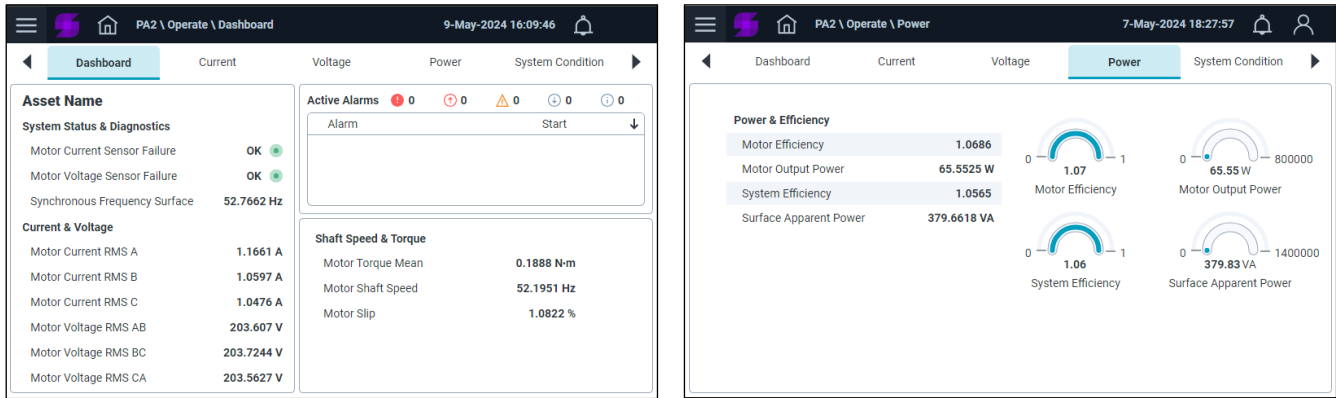

Figure 1.2—Local HMI display

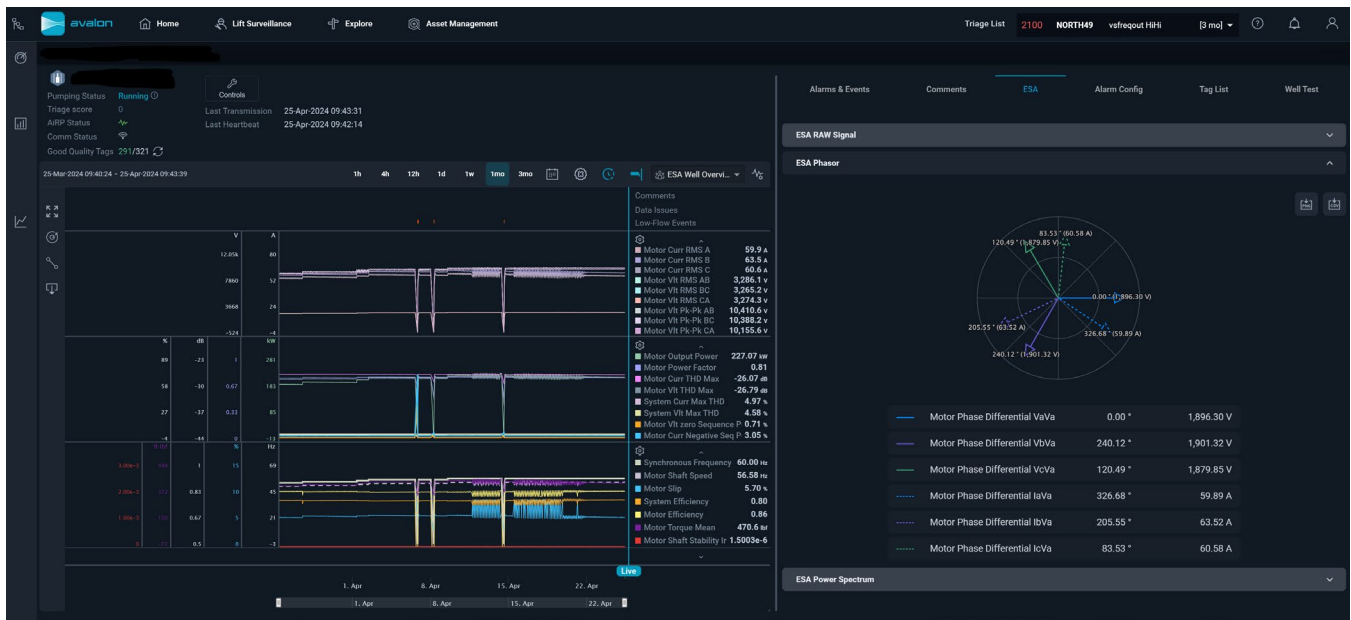

Figure 1.3—Data can be monitored remotely in Sensia’s Avalon interface via tabular displays and customizable trends and charts

**Note** Power Analyzer functionality is presented with “ESA” labels in Figure 1.3. These labels will be updated to reflect the Power Analyzer name in the next release of Avalon software.

## 1.2 ABOUT THIS DOCUMENT

This user manual is intended for field technicians and engineers and describes the installation, commissioning, configuration, monitoring, data analysis, and maintenance of the PA2.



### WARNING

Field engineers and technicians must have medium power certifications to install the PowerDAQ module and current sensors.

## 1.3 RELATED DOCUMENTS

INSTRUCT Power Analyzer 2.0 is an embedded edge application within the HCC2 precision-data acquisition and edge controller described in section 2.

For more information regarding the HCC2 controller or navigation of its Unity Edge interface used to configure and monitor the Power Analyzer 2.0, see the following documents:

- [QRATE HCC2 Hardware User Manual](#) (click the link, scroll to the bottom of the screen, and click “Manuals & Support”)
- [QRATE HCC2 Software User Manual](#) (click the link, scroll to the bottom of the screen, and click “Manuals & Support”)
- INSTRUCT ESP Intelligent Controller Installation, Operation & Maintenance Manual

## Section 2: System Requirements

This section describes the hardware, data and measurement, and communication requirements of the PA2 application.

### 2.1 HARDWARE REQUIREMENTS

The PA2 application runs in the Sensia HCC2 controller and requires the following hardware:

- HCC2 controller
- PowerDAQ module
- current sensors
- installation cables

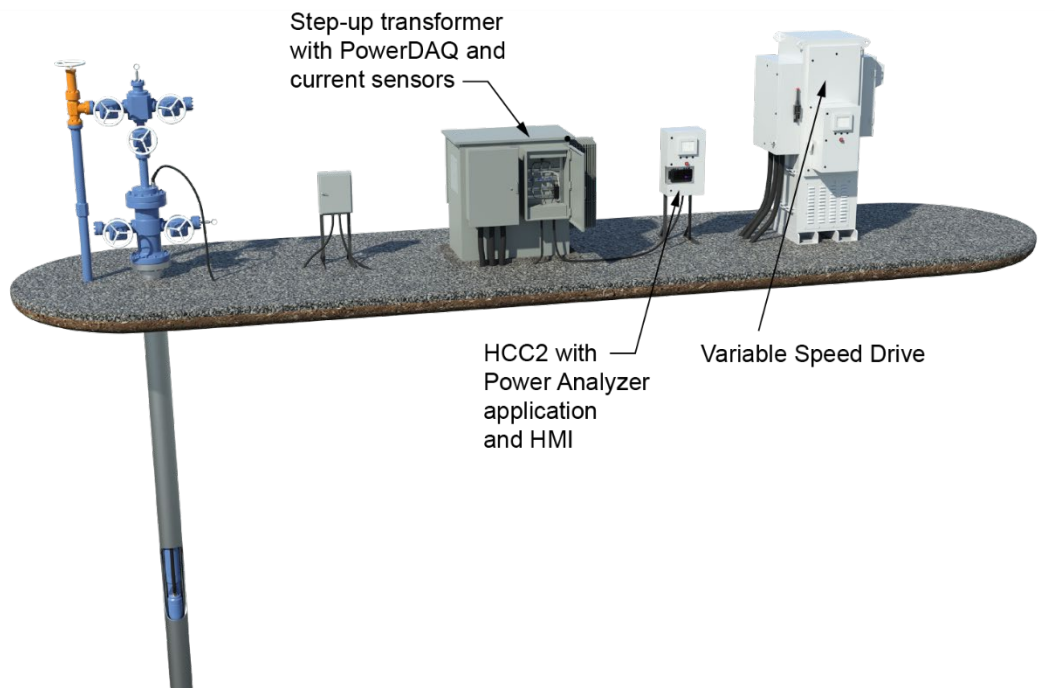

**Figure 2.1—Typical INSTRUCT Power Analyzer 2.0 wellsite installation**

#### 2.1.1 HCC2 Controller

The Power Analyzer is an embedded application within the HCC2 precision-data acquisition and edge controller. For PA2 installations, the HCC2 controller is mounted inside a NEMA 4X cabinet with an HMI installed in the door. The HCC2 cabinet may be located near the step-up transformer and the variable speed drive, or mounted to the side of a VSD.

The HCC2 is designed for high-speed operation in harsh environments and is suited for applications with wide temperature range and low-power consumption requirements.

The HCC2 can operate as an RTU/PLC, edge device controller and gateway, or as part of a larger integrated network of automation technologies. The data it acquires can be used locally for control or remotely for alarm and event reporting and remote data analytics.

See [Appendix F](#) for HCC2 assembly part numbers. HCC2 assemblies with the PA2 application are pre-wired at the factory to simplify field installation. A hole will need to be drilled in the enclosure to bring in an AC power cable during field installation.



**Figure 2.2—HCC2 Controller cabinet with a local HMI in the door panel (left and right images); an interior view (middle image) shows the location of the HCC2 controller**

**Note** Disregard the red light in the enclosure door below the HMI compartment. It is for future use and does not support the existing PA2 application.

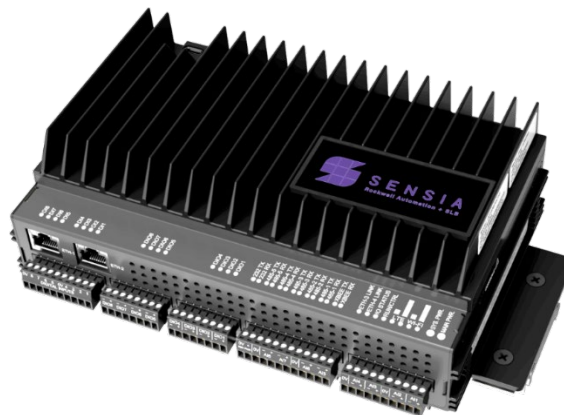

**Figure 2.3—HCC2 controller loaded with the Power Analyzer 2.0 application**

**Table 2.1—HCC2 Controller Cabinet Specification**

Feature	Functional Description
Standards	IEC 62208
	NEMA classification 13
	NEMA classification 4X
Certifications	UL
IP Protection	IP66 IEC 60529
IK Protection	IK10 IEC 62262
Fire Resistance	1760°F (960°C) IEC 62208
Ambient Air Temp	-40...176°F (-40...80°C)

For more information, please see the [QRATE HCC2 Hardware User Manual](#).

### 2.1.2 PowerDAQ Module

The PowerDAQ Module ([Figure 2.4](#)) is an interface between high-voltage inputs and the HCC2 and is typically installed inside a step-up transformer cabinet, medium-voltage drive (MVD), or a nearby junction box. It performs the following functions:

- acquires data/signals from VSD and/or step-up transformers
- steps down the signals to low-voltage signals
- transmits the low voltage signals to the HCC2 for processing
- serves as an interface between the HCC2 and the current sensors, providing +/-15VDC to the current sensors and acquiring current signals from the current sensors

Connection ports and pinout details are provided in [Table 2.2](#).

**Figure 2.4—PowerDAQ Module****Table 2.2—PowerDAQ Connection Ports**

Port	Functional Description
Va, Vb, Vc	Three-phase voltage signal inputs
Earth	Earth Ground connection
J1	HCC2 IO board analog inputs (see pinout below)
J2	+/-15VDC power supply input (see pinout below)
J3	Three current sensor connections (see pinout below)

		PIN No.	Signal Name	Description
J1 Pinout:		J1-1, J1-3, J1-5	GND	Current Signal Ground
		J1-2	IA_DAQ_P	Phase A Current Sensor Signal
		J1-4	IB_DAQ_P	Phase B Current Sensor Signal
		J1-6	IC_DAQ_P	Phase C Current Sensor Signal
		J1-7	VA_DAQ_N	Phase A Voltage Signal Return
		J1-8	VA_DAQ_P	Phase A Voltage Signal
		J1-9	VB_DAQ_N	Phase B Voltage Signal Return
		J1-10	VB_DAQ_P	Phase B Voltage Signal
		J1-11	VC_DAQ_N	Phase C Voltage Signal Return
		J1-12	VC_DAQ_P	Phase C Voltage Signal
J2 Pinout:		J2-1	V+	+15V Power Supply Input
		J2-2	GND	+15V/-15V GND
		J2-3	V-	-15V Power Supply Input
J3 Pinout:		J3-1, J3-4, J3-7	+15V	+15V Power for Current Sensor
		J3-3, J3-6, J3-9	-15V	-15V Power for Current Sensor
		J3-2	CS1	Phase A Current
		J3-4	CS2	Phase B Current
		J3-6	CS3	Phase C Current

**Table 2.3 PowerDAQ Module Specification**

Item	Specification
Part Number	50392120
Mounting	Indoor - NEMA 1 enclosure Outdoor - NEMA 3R or NEMA 4X enclosure
Dimensions	4.25 in (108 mm) H x 8.5 in (216 mm) W x 1.75 in (44.5 mm) D
Weight	1 lb (0.454 kg)
Power Supply	DC (Input) +15VDC, -15VDC, +/-3%, 400mA
High Voltage Inputs	5000 volts AC CATIII
Current Input to External Current Transducers	250 ARMS

Item	Specification
Maximum Altitude	1,000 meters above sea level
Temperature	Operating -40°C to +75°C (-40°F to +167°F )
	Storage -40°C to +75°C (-40°F to +167°F )
Approvals, Certifications, and Declarations	cUL, UL, CE
RoHS Compliance	Compliant

### 2.1.3 Current Sensors

A current sensor, often referred to as a current transformer (CT), measures the electric current flowing from the VSD output and/or the Step-Up transformer to the load (ESP Motor). The PA2 application employs three current sensors (one for each phase - A, B, C) installed on the motor cables that are connected to the Step-Up transformer bushings. These sensors operate on the principle of electromagnetic induction, where the current passing through a primary conductor induces a proportional current in a secondary winding. This secondary current can then be monitored or measured to determine the primary current.

These current sensors use a closed-loop Hall effect design to accurately measure the phases and generate an output current proportional to the primary current being measured. This output is subsequently wired to the PowerDAQ module. Importantly, this output is isolated from the primary current (AC), ensuring safety and accuracy.

**Table 2.4—Current Sensor Specifications**

Item	Specification
Current Ratio	800:01:00
Bore Size	30.2mm
Sensor Technology	Closed Loop Hall Effect
Supply Voltage	External DC Bipolar
Supply Voltage	15 to 24 V
Nominal Value	500A
Input Current	800A
Secondary Nominal Signal	Instantaneous 100 mA
Output Current	100 mA Arms
Primary Signal	AC + DC
Accuracy	0.6%
Overall Height	70.3mm
Overall Width	80mm
Overall Depth	40mm
Minimum Temperature	-40°C
Maximum Temperature	+70°C
Mounting Type	Panel Mount
Country of Origin	CN

## 2.1.4 Installation Cables

The PA2 application uses a series of cables to connect the main components of the system. Quick connectors facilitate installation. These cables are used to

- power the PowerDAQ module and the current sensors from the  $\pm 15\text{VDC}$  power supplies installed in the controller cabinet
- transmit all voltage and current signals transduced by the PowerDAQ module to the controller's analog inputs for high-frequency measurement
- generate the calculated parameters required by the PA2 application

Three cables are required to connect the PowerDAQ and sensors to the HCC2 controller.

1. Wiring from the HCC2 cabinet is bundled in a 1-meter cable and wired to a 21-position connector inserted in the bottom of the HCC2 controller cabinet.
2. Likewise, wiring from the PowerDAQ is bundled in a 1-meter cable and wired to a connector inserted in the wall of the high-voltage step-up transformer cabinet.
3. A longer cable – your choice of 8 m or 20 m length – completes the connection between the wall of the PowerDAQ cabinet and the bottom of the HCC2 controller cabinet.

All three cables are fitted with quick-connect adapters to make installation effortless and minimize downtime if a cable should be damaged and need to be replaced.

See the wiring diagram in [Appendix C](#) for details.

**Table 2.5—Cable Assembly Specifications**

Item	Description	Diameter (in.)
Component 1	9 X 1 pair	
Conductor	20 (7/28) AWG tinned copper	0.038
Insulation	0.016" wall, nom. PVC	0.07
Pair	2/cond cabled together	
Twists	6.0 twists/foot (min)	
Cable Assembly	9 components cabled	
Twists	1.9 twists/foot (min)	
Orientation	Components to be arranged from inside layer to outside layer	
Core Wrap	Nonwoven polyester tape, 20% overlap, min.	
Shield	A/P/A tape, 20% overlap, min.	
Drain Wire	20 (7/28) AWG tinned copper	
Braid	Tinned copper, 70% coverage, nom.	
Jacket	0.032" wall, nom., PVC	0.515 (0.536 Max.)
Color(s)	Slate, black, yellow, orange, blue, green, red, sand beige, white	
Ripcord	1 end 810 Denier nylon	
Print	XTRAGUARD(R) 1 shielded (UL) type CM 105°C SUN RES	
	or AWM 2464 80°C 300V or AWM 2517 105°C 300V	
	VW-1 or C(UL) type CMG 105°C FT4 CE ROHS	
	Oil resistant (SEQ footage)	
	* = Factory Code	
	[Note: Product may have c(UL) or CSA markings depending upon plant of manufacture.]	
Temperature	-35 to 105°C	

Features	Provides resistance to oils per UL Oil Res I (60°C Oil Res) and Class 43 UL sunlight resistant Provides exceptional protection against EMI interference when Supra-Shield is specified	
----------	---	--

## 2.2 SOFTWARE REQUIREMENTS

The INSTRUCT Power Analyzer 2.0 application is pre-installed in the HCC2 controller prior to shipment, and every PA2 system ships from the factory with a valid user license. This license is required for configuring and monitoring a PA2 application.

To avoid a gap in service, note the app license expiration date in the Unity Edge software interface (Figure 2.5) and process a Sensia license renewal before that date.

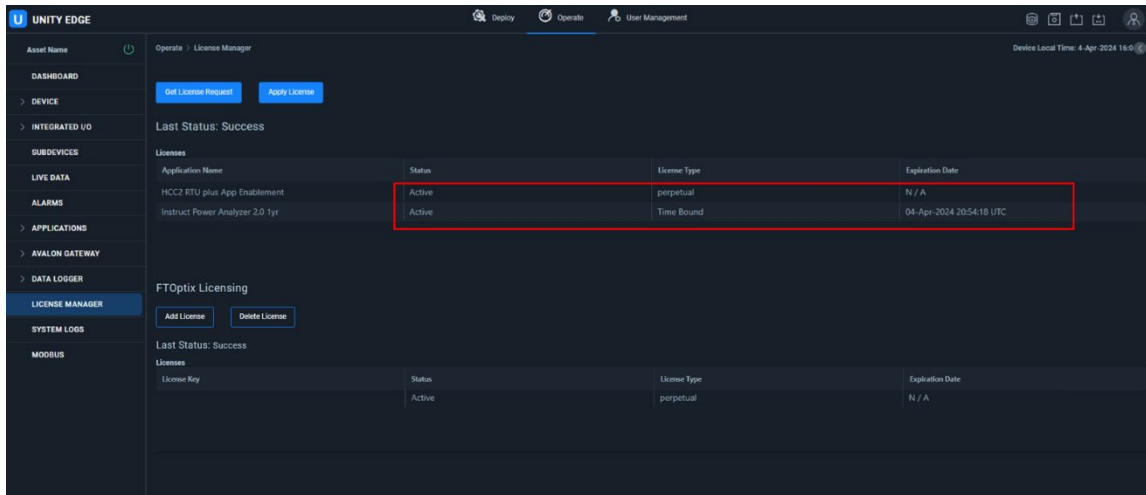

Figure 2.5—Unity Edge License Manager displaying license expiration date

See the License Manager information in the [QRATE HCC2 Software User Manual](#) for additional details and contact your Sensia representative for information on licensing options.

## 2.3 DATA AND MEASUREMENT REQUIREMENTS

This section covers the data and measurement requirements for a PA2 application.

### 2.3.1 Motor Design Data

The PA2 application requires a combination of measured inputs and calculated inputs. Many of these parameters come from calculated variables based on the motor design and its installation conditions. Once the motor design data are obtained from the customer, the values are calculated and entered into the Unity Edge PA2 configuration screens during commissioning.

Sensia will work with customers to produce calculated variables as follows:

1. Sensia will provide customers with a form that specifies the required motor and installation design details (requirements can vary based on the pump manufacturer).
2. The customer will complete the required inputs and submit the form to Sensia.
3. Sensia will perform an analysis to generate the calculated parameters.

4. The field engineer/technician will enter the calculated parameters into the Unity Edge interface as explained in section 5.3.2 Configure the Power Analyzer 2.0 Application.

**Important** To avoid commissioning delays and allow time for the detailed motor design data analysis, the customer should provide motor design data to Sensia at least one week prior to commissioning.

Below is an example of the motor data inputs required for these calculations. Parameters identified as optional will improve the accuracy of calculated outputs such as efficiency, but are not technically required. If no value is provided for these parameters, a default value or estimate will be used.

**Table 2.6—Motor Design Data for Calculations**

Inputs	Units	Type
Full Load Amps	A	Mandatory
Name Plate Voltage	V	Mandatory
Motor Series	-	Mandatory
Motor Output Power	HP	Mandatory
Number of Rotors	-	Mandatory
Number of Stator Slots	-	Optional
Turns per Slot	-	Mandatory
Parallel Wire per Slot	-	Mandatory
Motor Wire AWG	-	Mandatory
Reda Oil Number	-	Mandatory
Bottom Hole Temperature	°C	Mandatory
Wellhead (Tubing) Temperature	°C	Mandatory
Winding Temperature Increase	°C	Mandatory
Tubing Cable Resistance	Ohm/km	Mandatory
Tubing Cable Inductance	H/km	Mandatory
Tubing Cable Length	m	Mandatory
Jumper Cable Resistance	Ohm/km	Optional
Jumper Cable Inductance	H/km	Optional
Jumper Cable Length	m	Optional
Surface Cable Resistance	Ohm/km	Optional
Surface Cable Inductance	H/km	Optional
Surface Cable Length	m	Optional
PWM Frequency	Hz	Mandatory
Nominal Drive Frequency	Hz	Mandatory
Number of Pole Pairs	-	Mandatory
Number of Rotor Bars	-	Mandatory
Stator Inner Diameter	m	Optional
Rotor Cylinder Length	m	Optional
Rotor Outer Diameter	m	Optional

See [Table 5.1](#) for a list of measured and calculated inputs.

### 2.3.2 Inputs for Synchronous Acquisitions

The PowerDAQ module is connected to the step-up transformer to collect three-phase voltage and current readings. These measurements are required to enable the PA2 calculation engine to monitor and run the algorithms to produce calculated data.

---

Note When no transformer is on site, as when a Medium Voltage Drive (MVD) is in use, the PowerDAQ module is connected directly to the output of the line filter.

---

### 2.3.3 Voltage and Current Measurement

The PA2 Application requires a PowerDAQ Module and three external current sensors to measure high-frequency data of three-phase voltage and current measurements.

The PowerDAQ acquires three-phase high-voltage data/signals (up to 5000VRMS, phase to phase) from a drive and/or step-up transformers. It provides +/-15VDC to each current sensor and receives stepped-down current signals from each current sensor. The PowerDAQ then transmits the low-voltage/current signals to the HCC2 analog inputs.

Current sensors convert raw signals to low-current signals, and burden resistors convert the low-current signals into voltage signals that feed the HCC2 analog inputs.

For technical specifications, please see [Table 2.3](#).

## 2.4 COMMUNICATION REQUIREMENTS

The PA2 application communicates with multiple systems and devices through the HCC2 communication ports. For specifications and information on configuration of communications, see the [QRATE HCC2 Software User Manual](#).

### 2.4.1 Ethernet Communications

The HCC2 has four Ethernet ports available ([Table 2.7](#)). All four ports support automatic Medium Dependent interface (MDI) and Medium Dependent Interface with Crossover (MDIX) and auto-negotiate duplex and speed.

**Table 2.7—HCC2 Ethernet Ports**

Port Name	Performance	Recommended Use
ETH-1	10BASE-Te 100BASE-TX 1000BASE-T	Internet/remote connectivity and configuration (e.g., Unity Edge Interface, Avalon / ConnectedProduction)
ETH-2	10BASE-Te 100BASE-TX 1000BASE-T	Client SCADA / LAN / Field LAN. (e.g., Drive controller, choke actuator)
ETH-3 & ETH-4 Switched ports. Same IP address.	10BASE-Te 100BASE-TX	Embedded switch for device and field networks. (e.g., Device Level Ring (DLR), CIP connected devices.

### 2.4.2 Serial Communication

For PA2 applications, Sensia recommends the use of port RS485-3 for serial communications.

If other surface equipment also requires serial communications with the HCC2, you can use any of four other RS485 serial ports or the isolated RS232 serial port provided by the HCC2 ([Table 2.8](#)).

**Table 2.8—HCC2 Serial Ports**

Port Name	Transmission	Recommended Use
<b>RS485-1</b>	Full duplex (4 wires)	Acquisition (HCC2 as Modbus master) from field devices using 4-wire RS-485 (e.g., Drive controller, choke actuator)
<b>RS485-2</b>	Half duplex (2 wires)	Field devices (e.g., Drive controller, choke actuator)
<b>RS485-3</b>	Half duplex (2 wires)	Preferred for integrating INSTRUCT controller with HCC2 in PA2 applications (e.g., downhole data, surface instruments, VSD data)
<b>RS485-4</b>	Half duplex (2 wires)	Embedded switch for device and field networks. (e.g., Device Level Ring (DLR), CIP connected devices.)
<b>RS485-5</b>	Half duplex (2 wires)	General use
<b>RS232</b>	Full duplex (4 wires)	General use

### 2.4.3 Avalon Communications

To stream PA2 data in Avalon, you will need

- a wireless HCC2
- a laptop with internet communication
- an Avalon asset for monitoring and analyzing well data
- instructions for provisioning the HCC2 to stream data to Avalon

#### Cellular Communications

If you have a wireless HCC2 model, you can use the internal cellular modem to remotely connect to the Avalon platform without a traditional local network infrastructure. The HCC2 cellular radio module ships from the factory ready for field deployment with a micro-SIM card installed and cellular settings preloaded. Details on how to change the cellular modem configuration using the Unity Edge interface are available in the [QRATE HCC2 Software User Manual](#) (section 2.7).

For information about other network communications, see section 2.3 of the [QRATE HCC2 Software User Manual](#).

#### Avalon Asset Requirements

Sensia Technical Support will create an asset for each customer well using these three identifiers:

- Company name
- Field name
- Well name

The asset must be created in Avalon before you attempt to provision the HCC2. The asset should be available when the well is ready for commissioning. Contact Sensia Technical Support to confirm the asset setup.

#### Provisioning Instructions

For provisioning instructions, see [5.4 Provision the HCC2 Controller](#). Troubleshooting instructions are also provided in [section 9.1.3](#).

# Section 3: Theory of Operations

## 3.1 HIGH-LEVEL OPERATIONS

Electrical submersible pumps (ESPs) are driven by a downhole motor. The motor is driven from surface via a long, and in some cases, asymmetrical cable. The motor power is scalable to the application and consists of a stack of induction motors with no defined angular alignment of stators or rotors. A shaft couples the motor torque to a centrifugal pump to overcome the hydrostatic pressure to lift the formation fluid to surface.

The formation fluid can vary greatly in density and viscosity depending on the fluid composition. Typically, the fluid is a mixture of oil and water, but it can be a gas or have a multi-phase consistency. Changes in fluid properties are possible, but typically occur slowly. The pump operation can still vary with higher dynamics when sanding occurs. Since all equipment must fit into the well, the motor shaft is very long and susceptible to torsional oscillation.

The surface equipment consists of a variable speed motor drive with a sine wave filter on its output to eliminate pulse reflections in the motor cable, and a three-phase transformer to step up the output voltage.

The acquisition system includes a PowerDAQ module and three external current sensors to transduce the available raw voltage and current data to feed the HCC2. The HCC2 has synchronous acquisition channels with processing capability to extract performance parameters which are stored internally and used to run the PA2 engine.

The PA2 engine monitors six inputs (three-phase current and voltage) at a high frequency rate and runs internal algorithms to enable features including Power Quality Monitoring (PQM), system condition monitoring, independent backspin analysis, and true shaft speed and torque modelling.

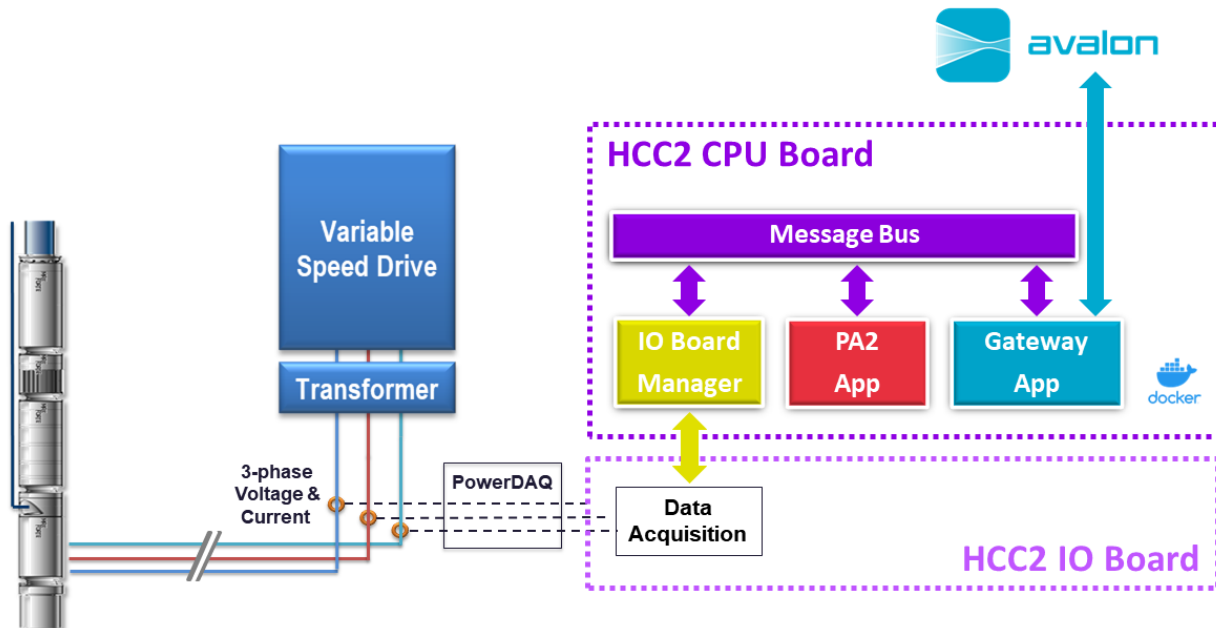

Figure 3.1—Power Analyzer 2.0 Diagram

The PA2 application can help you to maximize production, extend equipment life, and identify performance improvements for future system designs by leveraging prognostic health monitoring skills, motor startup optimization techniques, and diagnostic and post-mortem analysis. See details below.

### 3.1.1 Prognostic Health Monitoring

Prognostic health monitoring (PHM) is designed to detect developing problems early before they become catastrophic and to provide an estimate of remaining equipment life before servicing must be scheduled. PA2 is a tool to assist end users with PHM. For a list of parameters that are typically monitored for trends and potential escalations, see [Table 3.1](#).

### 3.1.2 Optimization

Motor start-up can be optimized based on observations of torque and speed. Operation can be optimized by operating in a more efficient region of the pump performance curve (input torque/speed versus output pressure/flow), optimizing voltage, or pumping at higher power without exceeding a known safety margin.

The PA2 application also enables motor power efficiency optimization as different operation points can be characterized and compared more clearly throughout the life of the ESP.

### 3.1.3 Diagnostic and Post-Mortem Analysis

Operation monitoring provides detailed information about specific types of failure and can help operators detect sub-optimal performance due to component degradation. In case of catastrophic failure, the PA2 application can support root cause analysis, which aids in future design improvements.

The data analysis consists of three main categories:

Data Analysis	Description
Motor Drive Performance Monitoring	Allows assessment of the quality of system operation
Motor Current Signature Analysis (MCSA)	A frequency domain analysis used to estimate motor speed or assess damage to the motor
Motor Parameter Tracking	Enables better estimates of motor torque, real time speed, and motor temperature

The PA2 Application package may complement or substitute part of downhole instrumentation for cost savings or improved performance monitoring.

## 3.2 POWER ANALYZER 2.0 OUTPUTS

The PA2 engine provides calculated outputs based on the analysis of high frequency data gathered by the PowerDAQ module and the HCC2.

See [Table 3.1](#) for a list of measured and calculated output parameters that can be monitored for trends and potential escalations.

**Table 3.1—Measured and Calculated Outputs**

Tag Name	Unit	Description	Type	Purpose
Motor Current Sample A	A	Raw current phase A	Measured	Raw signal captured for qualitative assessment of the sine waveform, and validation of the order of all three phases of current during installation/commissioning
Motor Current Sample B	A	Raw current phase B	Measured	Raw signal captured for qualitative assessment of the sine waveform, and validation of the order of all three phases of current during installation/commissioning
Motor Current Sample C	A	Raw current phase C	Measured	Raw signal captured for qualitative assessment of the sine waveform, and validation of the order of all three phases of current during installation/commissioning

Tag Name	Unit	Description	Type	Purpose
Motor Voltage Sample A	V	Raw voltage phase A	Measured	Raw signal captured for qualitative assessment of the sine waveform, and validation of the order of all three phases of voltage during installation/commissioning
Motor Voltage Sample B	V	Raw voltage phase B	Measured	Raw signal captured for qualitative assessment of the sine waveform, and validation of the order of all three phases of voltage during installation/commissioning
Motor Voltage Sample C	V	Raw voltage phase C	Measured	Raw signal captured for qualitative assessment of the sine waveform, and validation of the order of all three phases of voltage during installation/commissioning
Motor Current Cal RMS Zero	A	Idle noise with VFD off	Calculated	Quality control for testing sensors
Motor Current Offset A	A	Motor current offset. High offset indicates sensor problems.	Calculated	If offset, there may be an open circuit or sensor problem.
Motor Current Offset B	A	Motor current offset. High offset indicates sensor problems	Calculated	If offset, there may be an open circuit or sensor problem.
Motor Current Offset C	A	Motor current offset. High offset indicates sensor problems	Calculated	If offset, there may be an open circuit or sensor problem.
Motor Current Peak To Peak A	A	Phase A peak current amplitude (max - min)	Calculated	Used for identifying Sensor, combined with (2*sqrt(2) times of RMS A). If something is wrong, check sinewave.
Motor Current Peak To Peak B	A	Phase B peak current amplitude (max - min)	Calculated	Used for identifying Sensor, combined with (2*sqrt(2) times of RMS B). If something is wrong, check sinewave.
Motor Current Peak To Peak C	A	Phase C peak current amplitude (max - min)	Calculated	Used for identifying Sensor, combined with (2*sqrt(2) times of RMS C). If something is wrong, check sinewave.
Motor Current RMS A	A	Phase A root mean square current amplitude	Calculated	Used for identifying Sensor, combined with Peak To Peak. If something is wrong, check sinewave.
Motor Current RMS B	A	Phase B root mean square current amplitude	Calculated	Used for identifying Sensor, combined with Peak To Peak. If something is wrong, check sinewave.
Motor Current RMS C	A	Phase C root mean square current amplitude	Calculated	Used for identifying Sensor, combined with Peak To Peak. If something is wrong, check sinewave.
Motor Voltage Peak To Peak AE	V	Peak amplitude relative to ground phase A	Calculated	Includes the Zero Sequence voltage (if any)
Motor Voltage Peak To Peak BE	V	Peak amplitude relative to ground phase B	Calculated	Includes the Zero Sequence voltage (if any)
Motor Voltage Peak To Peak CE	V	Peak amplitude relative to ground phase C	Calculated	Includes the Zero Sequence voltage (if any)
Motor Voltage RMS AB	V	Phase to phase RMS voltage AB	Calculated	Used for identifying Sensor, combined with Peak To Peak. If something is wrong, check sinewave
Motor Voltage RMS AE	V	Voltage RMS relative to ground	Calculated	Includes the Zero Sequence voltage (if any)
Motor Voltage RMS BC	V	Phase to phase RMS voltage BC	Calculated	Used for identifying Sensor, combined with Peak To Peak. If something is wrong, check sinewave
Motor Voltage RMS BE	V	Voltage RMS relative to ground	Calculated	Includes the Zero Sequence voltage (if any)
Motor Voltage RMS CA	V	Phase to phase RMS voltage CA	Calculated	Used for identifying Sensor, combined with Peak To Peak. If something is wrong, check sinewave

Tag Name	Unit	Description	Type	Purpose
Motor Voltage RMS CE	V	Voltage RMS relative to ground	Calculated	Includes the Zero Sequence voltage (if any)
Raw Current RMS A	A	Operational motor current RMS phase A	Calculated	Current calculated from the waveform
Raw Current RMS B	A	Operational motor current RMS phase B	Calculated	Current calculated from the waveform
Raw Current RMS C	A	Operational motor current RMS phase C	Calculated	Current calculated from the waveform
Motor Efficiency		Ratio of motor output power to motor input power	Calculated	Mechanical motor output power/ electrical motor input power
Motor Output Power	W	Estimated motor mechanical output power	Calculated	Motor Mechanical output power
Motor Shaft Speed	Hz	Precision estimate of motor shaft speed	Calculated	Actual motor output shaft speed (< Drive Frequency) (Hz) Indicates pump reaction to flow changes. Different to frequency
Motor Slip	%	Precision estimate of slip	Calculated	Ratio of normalized difference of actual Shaft Speed and Synchronous Frequency (0-1 or %) Difference between real shaft speed and drive frequency, normalized to drive frequency
Motor-Cable System Efficiency		Ratio of motor output power to surface power (pump not included)	Calculated	Efficiency of electrical system (0-1 or %) Mechanical output power/ drive output power (as measured at output of step-up transformer)
Motor Torque Mean	N·m	Effective motor output torque	Calculated	Motor output shaft torque considering losses (N.m) Indicates pump reaction to flow changes
Motor Voltage Offset AE	V	Voltage offset relative to earth	Calculated	Measures motor downhole telemetry DC supply
Motor Voltage Offset BE	V	Voltage offset relative to earth	Calculated	Measures motor downhole telemetry DC supply
Motor Voltage Offset CE	V	Voltage offset relative to earth	Calculated	Measures motor downhole telemetry DC supply
Motor Voltage Peak To Peak AB	V	Phase to phase peak value (max - min)	Calculated	Maximum - minimum peak phase to phase
Motor Voltage Peak To Peak AN	V	Phase A relative to neutral	Calculated	Does not include Zero sequence voltage
Motor Voltage Peak To Peak BC	V	Phase to phase peak value (max - min)	Calculated	Maximum - minimum peak phase to phase
Motor Voltage Peak To Peak BN	V	Phase B relative to neutral	Calculated	Does not include Zero sequence voltage
Motor Voltage Peak To Peak CA	V	Phase to phase peak value (max - min)	Calculated	Maximum - minimum peak phase to phase
Motor Voltage Peak To Peak CN	V	Phase C relative to neutral	Calculated	Does not include Zero sequence voltage
Motor Voltage RMS AN	V	Voltage RMS relative to neutral	Calculated	Does not include Zero sequence voltage
Motor Voltage RMS BN	V	Voltage RMS relative to neutral	Calculated	Does not include Zero sequence voltage
Motor Voltage RMS CN	V	Voltage RMS relative to neutral	Calculated	Does not include Zero sequence voltage
Surface Apparent Power		Power required for the drive	Calculated	Drive apparent power

Tag Name	Unit	Description	Type	Purpose
Surface Effective Power	W	Effective output power. How much power is taken from grid	Calculated	Effectively used power
Motor Current Spectrum Bin		Spectrum index number	Calculated	Depend on sampling frequency and number of samples in the FFT. Look for the dominant component in the signal quality. How much distortion.
Motor Current Spectrum Frequency	Hz	Spectrum frequency related to the index	Calculated	Depend on sampling frequency and number of samples in the FFT. Look for the dominant component in the signal quality. How much distortion.
Motor Current Spectrum Magnitude	dB	Spectrum magnitude related to the index	Calculated	Depend on sampling frequency and number of samples in the FFT. Look for the dominant component in the signal quality. How much distortion.
Motor Current THD A	dB	Performance phase A [dB] of operation (high in case of high flux current)	Calculated	Measure of combined saturation effect on magnetic components or drive performance
Motor Current THD B	dB	Performance phase B [dB] of operation (high in case of high flux current)	Calculated	Measure of combined saturation effect on magnetic components or drive performance
Motor Current THD C	dB	Performance phase C [dB] of operation (high in case of high flux current)	Calculated	Measure of combined saturation effect on magnetic components or drive performance
Motor Current THD Max	dB	Maximum current THD of 3 phases	Calculated	High THD indicates distortions in the waveforms related to increased saturation levels of magnetic components – this leads to inefficiencies Peak between A, B, or C
Motor Current THD Percentage Max	%	Maximum current THD of 3 phases	Calculated	Maximum current Total Harmonic Distortion of 3 phases in %
Motor Current THD Percentage A	%	Performance phase A [%] of operation	Calculated	The ratio of sum of energy of higher harmonics to the fundamental frequency
Motor Current THD Percentage B	%	Performance phase B [%] of operation	Calculated	The ratio of sum of energy of higher harmonics to the fundamental frequency
Motor Current THD Percentage C	%	Performance phase C [%] of operation	Calculated	The ratio of sum of energy of higher harmonics to the fundamental frequency
Motor Phase Differential IaVa	rad	Lag between current phase A and voltage phase A	Calculated	Nominal -30 to -40 degrees
Motor Phase Differential IbVa	rad	Lag between current phase B and voltage phase A	Calculated	Nominal -150 to -160 degrees
Motor Phase Differential IcVa	rad	Lag between current phase C and voltage phase A	Calculated	Nominal -270 to -280 degrees
Motor Phase Differential VaVa	rad	Lag between voltage phase A and voltage phase A	Calculated	Always 0 degrees as reference
Motor Phase Differential VbVa	rad	Lag between voltage phase B and voltage phase A	Calculated	Nominal -120 degrees (lag between voltage phases B and A)
Motor Phase Differential VcVa	rad	Lag between voltage phase C and voltage phase A	Calculated	Nominal -240 degrees (lag between voltage phases C and A)
Motor Power Spectrum Bin		Spectrum index number	Calculated	Depend on sampling frequency and number of samples in the FFT. Look for the dominant component in the signal quality. Determine amount of distortion.

Tag Name	Unit	Description	Type	Purpose
Motor Power Spectrum Frequency	Hz	Spectrum frequency related to the index	Calculated	Depend on sampling frequency and number of samples in the FFT. Look for the dominant component in the signal quality. Determine amount of distortion.
Motor Power Spectrum Magnitude	dB	Spectrum magnitude related to the index	Calculated	Depend on sampling frequency and number of samples in the FFT. Look for the dominant component in the signal quality. Determine amount of distortion.
Motor Shaft Stability Indicator Magnitude		Shaft stability indicator magnitude	Calculated	(Unitless, normalized) indication of bulk torsional vibration of the ESP string – helps assess relative levels of vibration for different operating conditions, and escalating levels indicating mechanical damage Derived from electrical signature analysis Shows the shaft stability. High magnitude means high vibration
Motor Voltage THD AB	dB	Performance phase to phase AB [dB] of operation	Calculated	Measure of combined saturation effect on magnetic components or drive performance
Motor Voltage THD BC	dB	Performance phase to phase BC [dB] of operation	Calculated	Measure of combined saturation effect on magnetic components or drive performance
Motor Voltage THD CA	dB	Performance phase to phase CA [dB] of operation	Calculated	Measure of combined saturation effect on magnetic components or drive performance
Motor Voltage THD Max	dB	Maximum voltage THD of 3 phases	Calculated	High THD indicates distortions in the waveforms related to increased saturation levels of magnetic components – this leads to inefficiencies
Motor Voltage THD Percentage Max	%	Maximum voltage THD of 3 phases	Calculated	Maximum voltage Total Harmonic Distortion of 3 phases in %
Motor Voltage THD Percentage AB	%	Performance phase to phase (A - B) [%] of operation	Calculated	The ratio of sum of energy of higher harmonics to the fundamental frequency
Motor Voltage THD Percentage BC	%	Performance phase to phase (B - C) [%] of operation	Calculated	The ratio of sum of energy of higher harmonics to the fundamental frequency
Motor Voltage THD Percentage CA	%	Performance phase to phase (C - A) [%] of operation	Calculated	The ratio of sum of energy of higher harmonics to the fundamental frequency
Synchronous Frequency Surface	Hz	Fundamental drive frequency	Calculated	Instantaneous drive frequency (Hz) Frequency set up on controller or VSD
System Current Max THD	%	Maximum current THD of 3 phases	Calculated	High THD indicates distortions in the waveforms related to increased saturation levels of magnetic components – this leads to inefficiencies
System Voltage Max THD	%	Maximum voltage THD of 3 phases	Calculated	High THD indicates distortions in the waveforms related to increased saturation levels of magnetic components – this leads to inefficiencies
Motor Voltage Negative Sequence	V	Measures the symmetry of the phase voltage given by matching amplitude and the nominal 120-degree phase shift.	Calculated	A higher number means the drive signal quality is bad and creating vibration, increasing losses. (opposite rotation force)

Tag Name	Unit	Description	Type	Purpose
Motor Voltage Positive Sequence	V	Measures the symmetry of the phase voltage given by matching amplitude and the nominal 120-degree phase shift.	Calculated	Nominal value is $\sqrt{2}$ times RMS phase Voltage. Smaller than nominal means losses (distortion) and vibration.
Motor Voltage Zero Sequence Percentage	%	Ratio between zero and positive Voltage sequence	Calculated	Indicates asymmetry to earth and developing single point leakage (e.g., in insulation) (0-1 or %) How much relative asymmetry to the Earth (percentage)
Motor Voltage Zero Sequence	V	Average of 3 phase voltages	Calculated	Indicates asymmetry to earth and developing single point leakage (e.g., in insulation) (0-1 or %) If not 0, means leakage (asymmetry) to the Earth and see fluctuation
Voltage Imbalance %	%	Negative sequence voltage to positive sequence voltage ratio (percentage)	Calculated	Drive voltage quality
Motor Current Negative Sequence Percentage	%	Negative sequence current to positive sequence current ratio (percentage)	Calculated	Indicates imbalance in phase impedance and developing multi point leakage (e.g., in insulation) (0-1 or %) Contributes to vibration, and losses and indicates leakages. Related to symmetry of the load impedance. (Current Imbalance %)
Motor Current Negative Sequence	A	Measures the symmetry of the phase current given by matching amplitude and the nominal 120-degree phase shift.	Calculated	Indicates imbalance in phase impedance and developing multi point leakage (e.g., in insulation) (0-1 or %) Contributes to vibration, indicates asymmetry and two-point or multi-point leakage
Motor Current Positive Sequence	A	Measures the symmetry of the phase current given by matching amplitude and the nominal 120-degree phase shift.	Calculated	Nominal value is $\sqrt{2}$ times RMS phase Current. Contributes to torque. Smaller than nominal means losses (distortion) and vibration.
Motor Current Zero Sequence	A	Average of 3 phase currents	Calculated	A large value indicates sensor failure. Should be zero if sensor is good.
Motor Current Zero Sequence Percentage	%	Ratio between zero and positive current sequence	Calculated	A large value indicates sensor failure. Should be zero if sensor is good.
Motor Power Factor		Ratio of effective to apparent power	Calculated	Ratio of real power to apparent power (0-1). Too low or too high a power factor leads to inefficient operation requiring increased current for a given load torque. Effective power at motor terminals. Indicates load level of the motor. A little bit lower than the surface, due to cable losses.
System Average Instantaneous Power	W	System average instantaneous power	Calculated	Measure system average power
Phasor Diagram			Custom chart	Generally, time series monitoring is sufficient at a first level. Phasors and Waveforms are useful for troubleshooting and deeper interpretation, as well as enabling qualitative assessments during setup and continuous operation.
Waveform			Custom chart	

## Section 4: Field Installation

Power Analyzer 2.0 is an embedded application in the HCC2 controller.

The HCC2 is one of several components required to enable the PA2 application to collect measurements, run the algorithms for calculations, and display the measured and calculated values for analysis.

This section describes the installation of these components.

Below is an overview of a typical ESP and INSTRUCT Power Analyzer 2.0 wellsite installation.

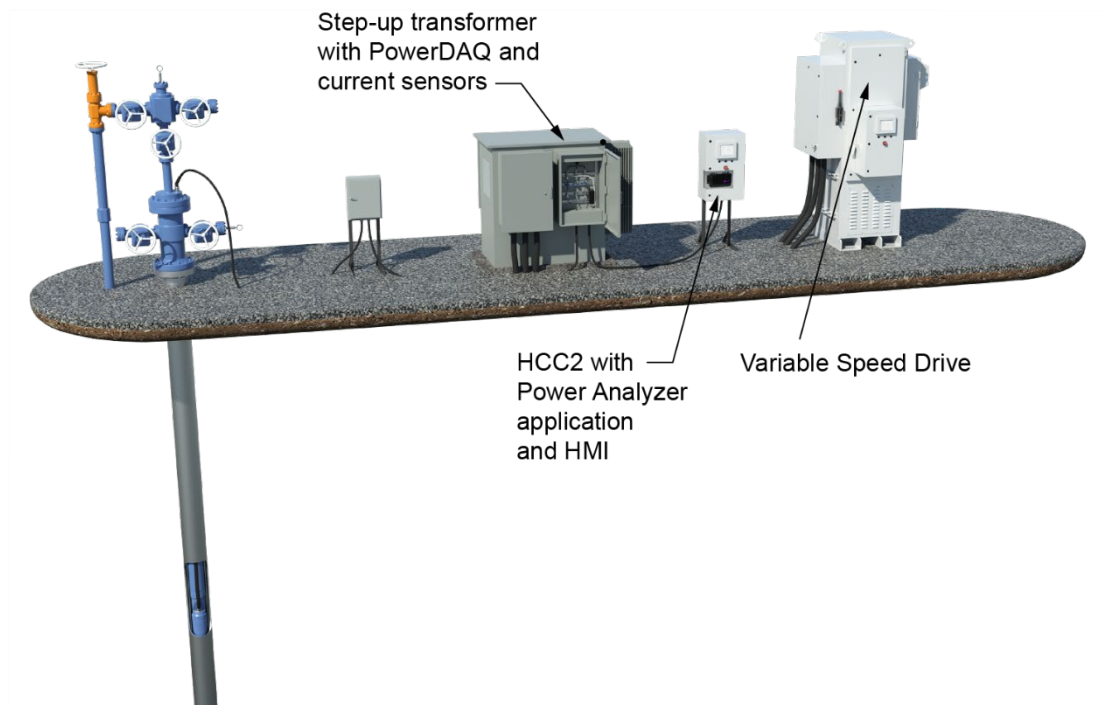

**Figure 4.1—Typical INSTRUCT Power Analyzer 2.0 wellsite installation**

### 4.1 REQUIRED TOOLS AND SITE PREPARATION

Before commencing installation of a Power Analyzer 2.0 system, take time to evaluate the installation plan and the tools, materials, and processes that are necessary to complete the job safely and efficiently.

1. Verify that your toolset includes:
  - screwdriver kit (Phillips & flat)
  - a tool for making a NEMA 1-1/4 NPT size knockout, such as a knockout punch driver or stepper bit  
This will be needed to install the PowerDAQ pigtail quick-connect cable in the wall of the step-up transformer cabinet. An NPT 1-1/4 hole has a diameter of 1.73 inches or 44mm.
  - colored tape in multiple colors  
This tape is useful for labelling the high-voltage PowerDAQ cables to match the colors associated with the corresponding phase outputs to reduce risk for wiring mistakes when making secondary transformer connections. Phase colors can vary by region and installation, so carrying tape in a variety of colors is recommended.
2. Obtain a permit to work or equivalent authorization to proceed.

3. Consult with your manager and/or safety officer regarding hazard and risk assessment for safe work on medium voltage (5000v) equipment.
4. Review and practice all applicable safety procedures such as lockout/tagout procedures.
5. Ensure that the work area is cleared for installation.
6. Select a suitable location for the HCC2 controller enclosure.
  - The enclosure should be level, stable, and securely anchored to prevent any unintended movement or tipping.
  - The distance between the HCC2 controller enclosure and the high-voltage transformer cabinet must not exceed the length of the wiring cable that connects the two cabinets. Sensia provides this cable in 8m and 20m lengths.
7. Finalize a plan to supply AC power to the HCC2 controller cabinet (typically from terminals in the VSD cabinet) and make sure you have appropriate tools and materials. There are no pre-drilled holes in the cabinet to facilitate a power conduit.

## 4.2 HCC2 CONTROLLER CABINET

1. Before proceeding with electrical connections, take the following safety precautions:
  - a. Verify that the cabinet's main power source is deenergized (use a multimeter). Typically, the main 100/240 VAC power source is supplied by the VSD (Variable Speed Drive) Step-down transformer terminal blocks in the VSD enclosure.
  - b. Verify that the fuse in the power terminal of the cabinet ([Figure 4.2](#)) is open. If the fuse is closed, open it to prevent electrical hazards during installation.
2. Drill a hole in the controller cabinet and install the 100/240 VAC power cable per the provided specifications and safety guidelines. Use appropriate tools and materials to ensure reliability and safety.
3. Connect the power cable to the AC power terminals of the cabinet, adhering to proper polarity guidelines ([Figure 4.3](#)). Tighten securely to prevent loosening or accidental disconnection.

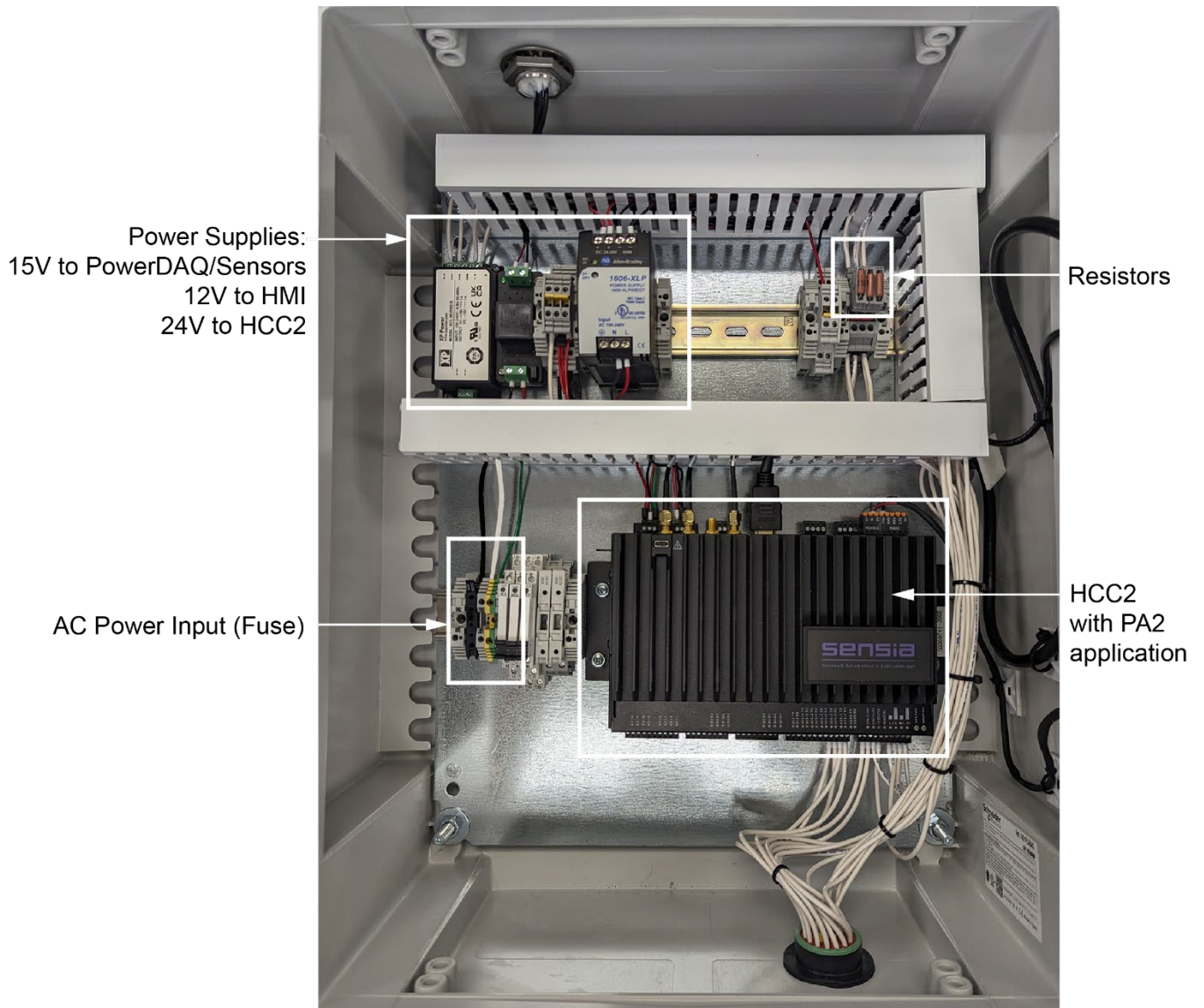
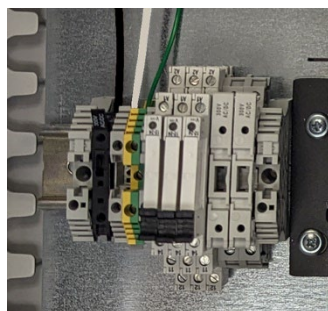

Figure 4.2—Controller cabinet components



Terminal	Type	Phase
1	Fuse	Line (black cable)
2	Feedthrough	Neutral (white cable)
3	Ground	Ground (green cable)

Figure 4.3—AC Power Connection in HCC2 Cabinet

### 4.3 POWERDAQ AND CURRENT SENSORS

Each PA2 application requires installation of a PowerDAQ and three current sensors (one per phase A, B, and C). These are typically installed in a step-up transformer cabinet.

A hole must be created in the transformer cabinet wall to facilitate cabling between the transformer and controller cabinets.

Install the PowerDAQ and sensors as follows:

1. Obtain the Permit to Work (PTW) and relevant Work Permit authorized by the corresponding entity.
2. Ensure that the work area is cleared for installation.
3. Power down the VSD/switchboard (or verify that it is powered down).



#### WARNING

Field engineers and technicians must have medium power certifications to install the PowerDAQ module and current sensors.

4. Use a high-voltage probe and appropriate PPE to ensure there is no voltage remaining in the high-voltage terminals.
5. Disconnect the motor/surface cable (the green cable in [Figure 4.4](#)) from the secondary (load-side) transformer bushings using a wrench or adjustable wrench.
6. To install the quick-connect fittings, drill a hole in the transformer cabinet wall using a knockout punch driver. This hole will facilitate cable connections between the transformer and controller cabinets as shown in [Figure 4.13](#), [Figure C.2](#), and [Figure C.3](#). Approximate hole dimensions are 1.69 in. (48.03 mm).
7. Place the PowerDAQ module on the bottom side of the transformer cabinet near the three-phase connections.

**Note** The PowerDAQ module can also be mounted inside a junction box. However, it is critical to note that the white silicone voltage leads will have medium-voltage potential on them. Consult local electrical code for requirements related to routing 5kV conductors between cabinets and take all necessary safety precautions.

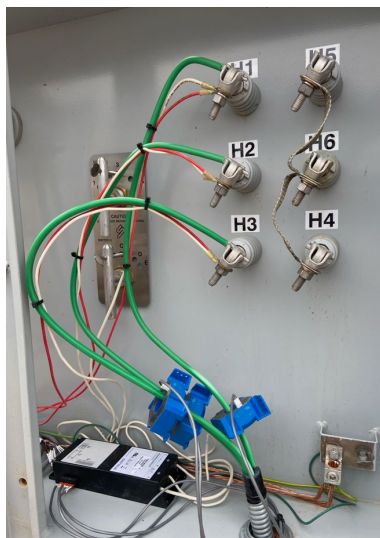

**Figure 4.4—PowerDAQ in secondary (load) side of transformer cabinet**

### 4.3.1 Install Sensors

1. Visually inspect the current sensors to verify their integrity.
2. Place the current sensors on each phase, ensuring that the flow arrow on each sensor aligns with the direction of current flow towards the motor (Load), as shown in [Figure 4.7](#).



Figure 4.5—Arrow indicating current flow direction

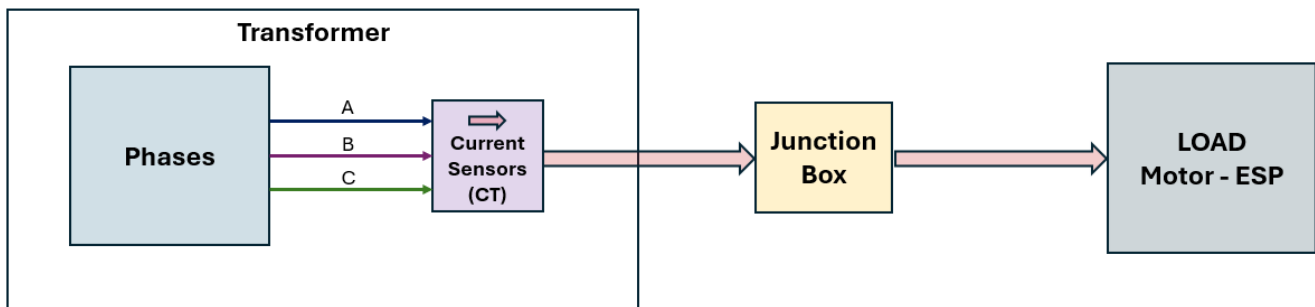

3. Ensure the current sensors are at least 13 centimeters (5 inches) from any medium-voltage contact—e.g., a secondary (load-side) transformer bushing ([Figure 4.6](#)).

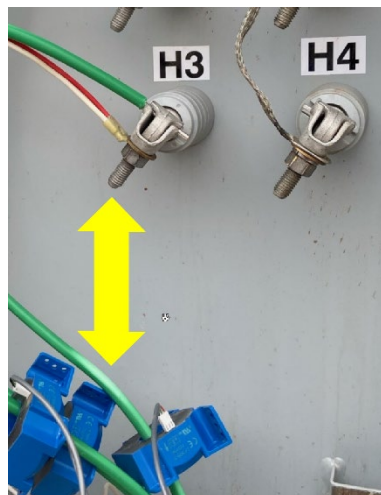
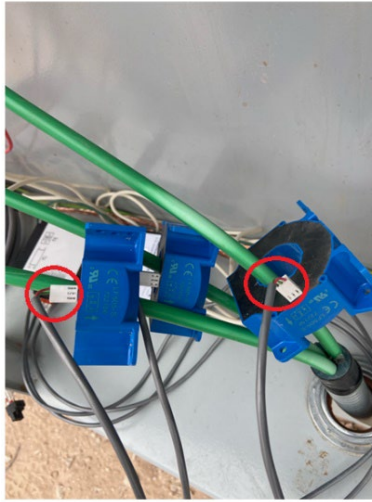

Figure 4.6—Required separation of sensors from transformer bushings

**WARNING – ELECTRICAL SHOCK**

Failure to mount the current sensors at least 5 inches (13 centimeters) away from the transformer connections may result in violation of safe creepage and clearance distances and create a serious electrical shock hazard.

- Once the current sensors are positioned on the phases, connect the PowerDAQ current sensor cable from the PowerDAQ module (gray cable with white connector) to the current sensors (Figure 4.7).



**Figure 4.7—PowerDAQ to current sensor connections**

- Apply colored tape to the high-voltage PowerDAQ cables to identify the output phase connection required for each cable. Pay close attention to the PowerDAQ label markings to ensure that each taped cable is color-matched to the appropriate phase (e.g., cable A tape is the same color as the Phase A color designation).
- Connect the high-voltage cables of the PowerDAQ (labeled A, B, C) to the step-up transformer output, matching cable A to Phase A, cable B to Phase B, etc. (Figure 4.8, left, and Table 4.1).
- Reconnect motor surface cables to normalize the connection (green cables in Figure 4.8, right).

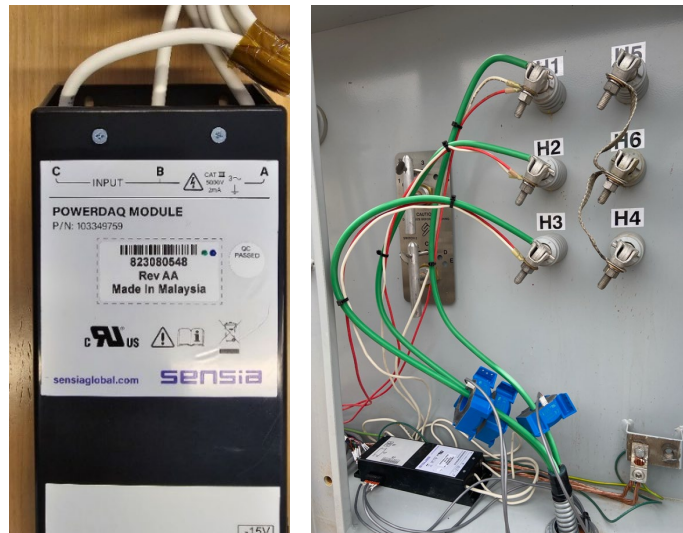

**Figure 4.8—PowerDAQ voltage cable (left) and output phase (right) connections**

**Table 4.1—PowerDAQ to Transformer Connections**

PowerDAQ	Transformer
A	Phase A or H1
B	Phase B or H2
C	Phase C or H3

### 4.3.2 Complete PowerDAQ Connections

1. Connect the PowerDAQ ground cable to the nearest grounding/armor bar (Figure 4.9). Ensure the connection is secure.

**Figure 4.9—PowerDAQ ground connection****WARNING**

Never operate the equipment with the ground terminal disconnected as this may create a potential shock hazard.

2. Wire the sensor power/signal cables to terminal block J3, checking for loose connections, bent pins, or other issues.



**Figure 4.10—Current sensor to PowerDAQ (J3) connection**

3. Ensure that the connectors are properly oriented and match the corresponding pins on the PowerDAQ module as shown in [Table 4.2](#).

**Table 4.2—Pinout Details for J3 Connection**

Wire Tag	PowerDAQ	Phase
-15V	-15V	PHASE C
Signal	CS3	PHASE C
+15V	+15V	PHASE C
-15V	-15V	PHASE B
Signal	CS2	PHASE B
+15V	+15V	PHASE B
-15V	-15V	PHASE A
Signal	CS1	PHASE A
+15V	+15V	PHASE A

4. Confirm that the cables are securely connected, and no gaps exist between the connectors and the PowerDAQ module.
5. Use the 1-meter bundled cable shown in [Figure 4.12](#) to connect the signal and power cables from the HCC2 controller system to the J1 and J2 ports of the PowerDAQ module, ensuring a snug fit to prevent disconnection.
  - J1 (HCC2 Analog Inputs signals)
  - J2 (+/-15VDC & Ground)

IA-DAQ_P	IB-DAQ_P	IC-DAQ_P	VA-DAQ_P	VB-DAQ_P	VC-DAQ_P
2	4	6	8	10	12
1	3	5	7	9	11
IA-GND	IB-GND	IC-GND	VA-DAQ_N	VB-DAQ_N	VC-DAQ_N

Figure 4.11—Port J1 signal terminations

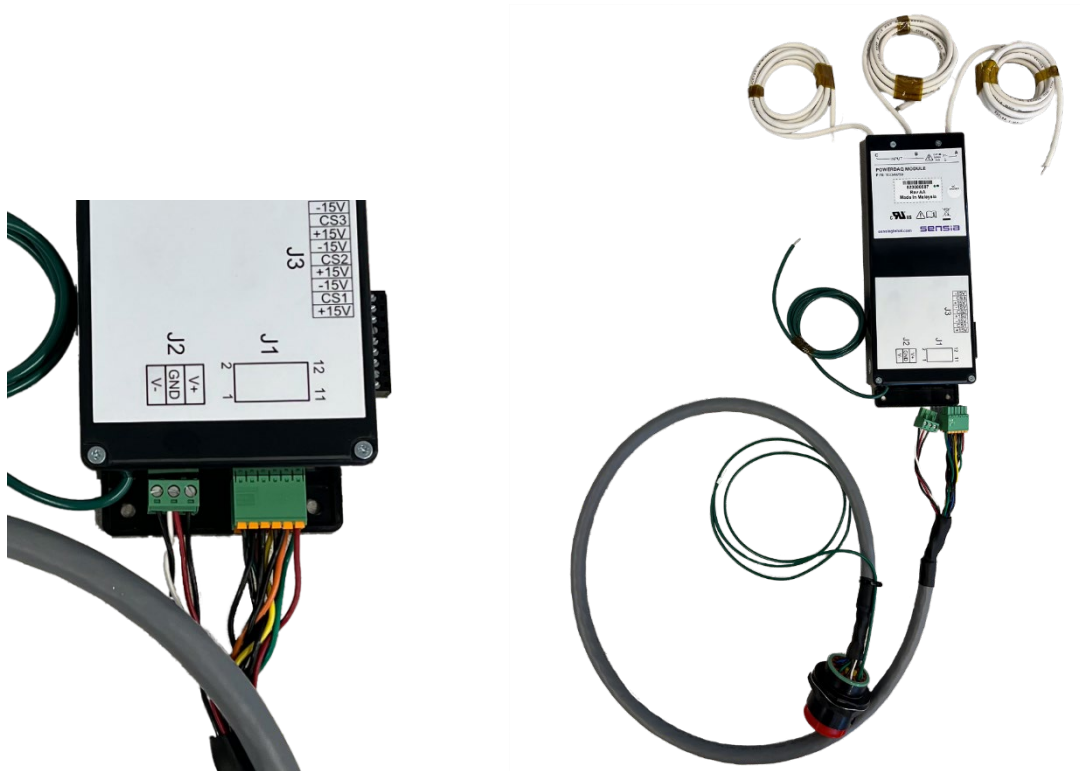

Figure 4.12—Cable connects PowerDAQ to HCC2 for transmission of analog input signals and power

6. Connect the other end of the 1-meter cable to the quick-connect adapter in the wall of the high-voltage transformer cabinet.
7. Use the longer quick-connect cable (8m or 20m) as shown in [Figure 4.13](#) to connect the wiring between the transformer/junction box (containing the PowerDAQ and sensors) and the HCC2 controller cabinet.



**Figure 4.13—Quick-connect fittings simplify wiring connections between the transformer cabinet and the HCC2 controller cabinet**

## 4.4 INTERNET CONNECTIVITY

To achieve the internet connectivity required to link the PA2 application to Avalon, you must enable the HCC2 internal cellular radio module.

The HCC2 cellular radio module ships from the factory ready for field deployment with a micro-SIM card installed and cellular settings preloaded.

To access the micro-SIM card slot, remove the metal slot cover from the left side of the HCC2.

For configuration instructions, see section 2.7 of the [QRATE HCC2 Software User Manual](#).

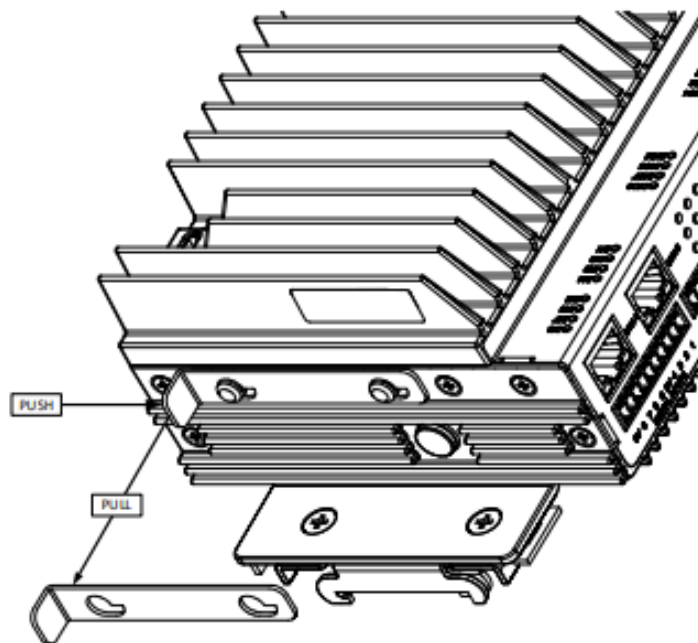

**Figure 4.14—HCC2 microSIM card access**

## Section 5: Commissioning

This section describes the workflow and the steps to carry out the commissioning and start-up of the PA2 application.

### 5.1 REQUIRED TOOLS AND PREPARATIONS

Before starting commissioning on site, field engineers should verify the following requirements are met:

1. Verify motor design data has been obtained from the customer. (This data should be provided to Sensia at least one week prior to commissioning.) See [section 2.3.1](#) for details.
2. Verify receipt of the calculated input settings from Sensia Technical Support.
3. Obtain a Permit to Work (PTW).
4. Review LOTO procedures as required.
5. Verify that the following items are available.
  - Laptop
  - USB-C to USB-A cable
  - Cat5/Cat6 Ethernet cable
  - Mechanical drawings (Appendix D)
  - Wiring Diagrams (Appendix C)
  - Multimeter
6. Acquaint yourself with the layout and navigation of HCC2's Unity Edge interface. You will use this interface to configure the PA2 application.
7. Confirm your login access to Avalon (for viewing data following commissioning, if desired).
8. Confirm the setup of the Avalon asset to be monitored. Sensia Technical Support will gather the necessary information to create this asset (company name, field name, well name) and will provide the hierarchy path necessary to provision the HCC2.

### 5.2 POWER ON THE HCC2 CABINET

1. Power up the VSD/Switchboard and verify that the supply voltage to the PA2 cabinet remains within the input voltage range under all operating conditions (100/240 VAC).
2. Ensure that the fuse in the PA2 cabinet's power terminal is closed.
3. Using a multimeter, check that the power supply reaching the power terminal is 100 VAC.
4. Verify the following power statuses:
  - The 24v, 15v and 12v power supplies must be powered on and feeding power to the HCC2 (24v), PowerDAQ/CTs (15v) and Local HMI (12v). See [Figure 4.2](#).
  - The 15v power supply must be providing power to the PowerDAQ within this range (measure the power supply output with a multimeter to confirm).
  - The HCC2 and the Local HMI must be powered ON.
5. Ensure that the Power Analyzer application is loaded on the local HMI in the door of the HCC2 cabinet and content is displayed on the touch screen.

- Press buttons on the HMI to verify touchscreen function. Screens should change with each button press.

## 5.3 CONFIGURE AND ENABLE THE PA2 APPLICATION

The Power Analyzer application will be loaded onto the HCC2 at the factory. This procedure guides you through the steps to configure and enable the application for data collection and monitoring,

### 5.3.1 Log in to HCC2 Web UI (Unity Edge)

- Once the system is energized, connect the laptop to the HCC2 using the USB-C to USB-A cable. Connect the USB-C connector to the HCC2 (Figure 5.1) and connect the USB-A connector to the laptop.

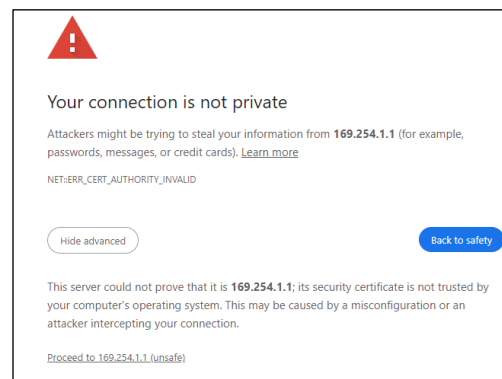
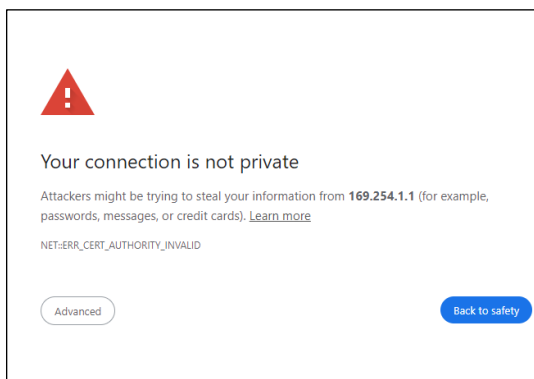

Figure 5.1—HCC2 USB-C connector for laptop connection

- Open a browser window in Incognito mode (Google Chrome) on the laptop and enter the IP address of the Unity Edge UI:

<https://169.254.1.1>

- Click the “Advanced” button and then “Proceed to 169.254.1.1 (unsafe)” as per the on-screen instructions.



4. Click “Log In” at the screen prompt.

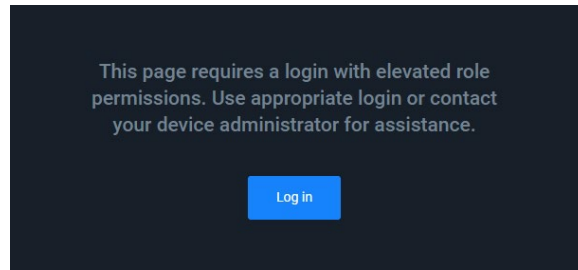

5. Enter the default username and password on first login and press Login to connect to the HCC2.  
Username: admin  
Password: SensiaHCC2#  
Change the password at the prompt.



#### CAUTION

Record the new password and keep it safe and accessible. You will have to supply it to allow access for Sensia troubleshooting support.

Note Contact Sensia Technical Support or refer to the [QRATE HCC2 Software User Manual](#) for assistance if needed.

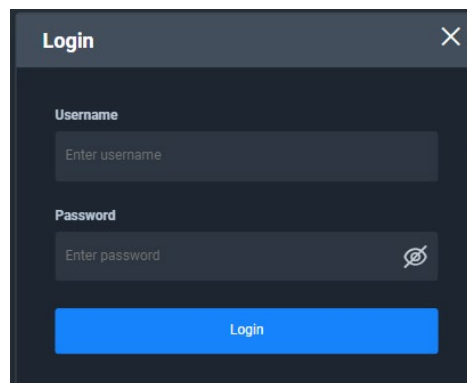

### 5.3.2 Configure the Power Analyzer 2.0 Application

Note The layout and navigation of the HCC2 Unity Edge interface is outside the scope of this manual. If you are a new HCC2 user, see the [QRATE HCC2 Software User Manual](#) for this information.

1. Verify the application is loaded and accessible.
  - a. Click the Deploy tab at the top of the screen and look for the PA2 application in the navigation tree on the left side of the screen. If it is not present, use the drop-down Select Applications menu to choose the application.
  - b. Click the Update Deployment File button in the bottom right corner of the screen.

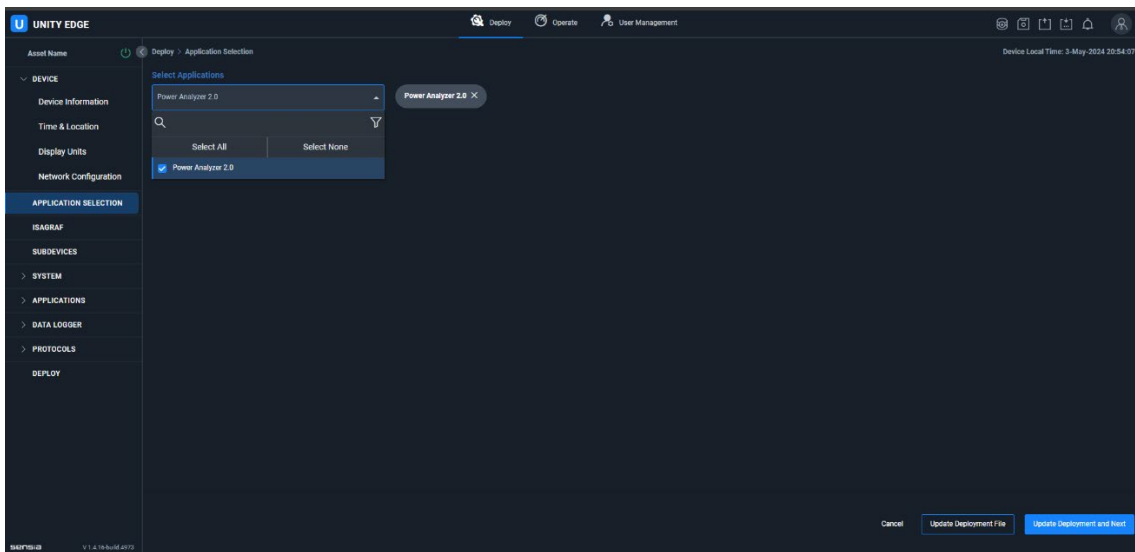

2. Verify the modes and ranges of the analog inputs as follows.
  - a. Select System>Integrated IO from the navigation tree.
  - b. Verify that the modes and ranges, especially for the Analog Inputs 1 through Analog Input 6, appear as shown in the screen below. Update if necessary.
  - c. Click the Update Deployment File button to proceed.

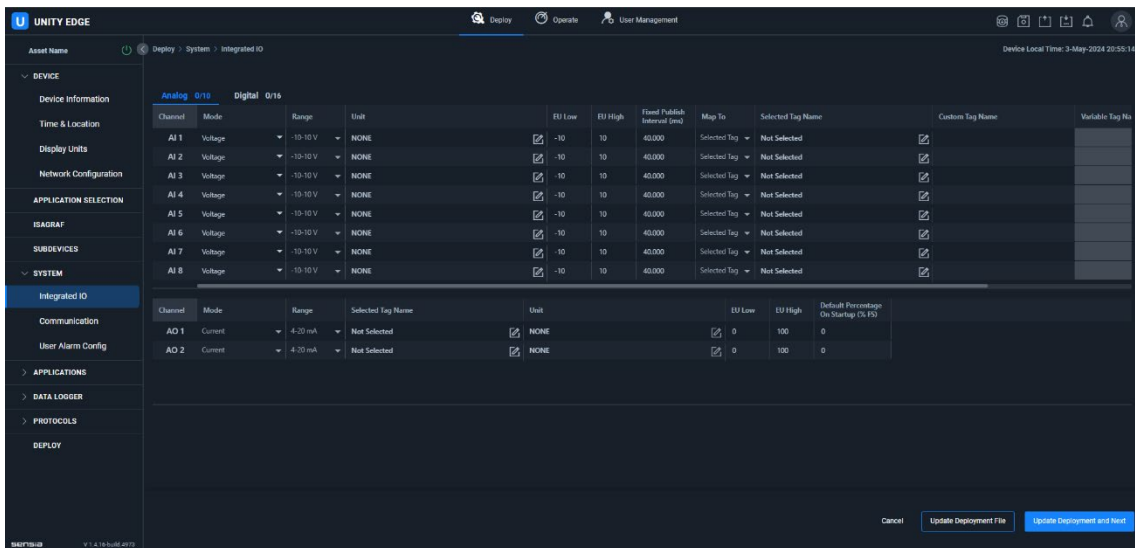

3. Verify units and decimal settings as follows.
  - a. Select Device>Display Units from the navigation tree.
  - b. Update the units and decimals for the following categories to match the contents of the table below.
    - Units are configurable to match local standards. Decimal point numbers can be changed, but for PA configuration, six-digit decimals should be retained for length, resistance, and inductance.
    - Current displays in milliamps by default. Change it to amps as shown.

Categories	Units	Decimals
Static Pressure (Gauge)	psig	0.000000
Temperature	°F	0.000000
Length	m	0.000000
Current	A	0.000000
Resistance	Ohm	0.000000
Inductance	H	0.000000

- c. Click the Update Deployment File button to proceed.

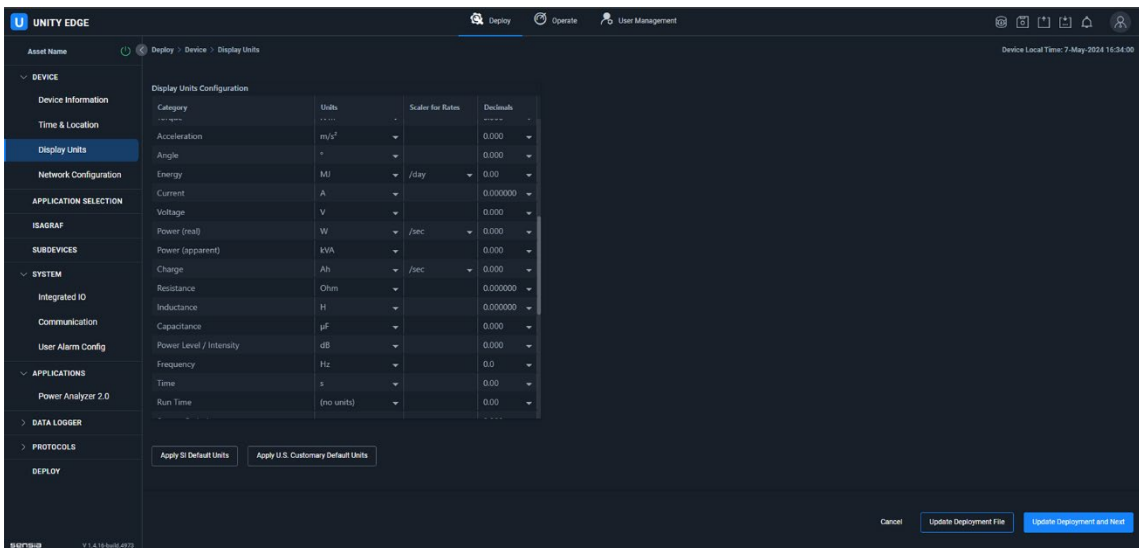

4. Enter input parameters.
  - a. Click Applications>Power Analyzer 2.0 in the navigation tree.
  - b. Enter the PA2 input parameters and update settings as required to reflect the current installation. This may include calculated inputs as described in [Table 5.1](#).



**CAUTION**

Configuration parameters differ among motor designs. Changes made to the motor or other downhole equipment prior to startup can affect the accuracy of calculated inputs. Always revalidate motor data and calculated inputs following any change to this equipment. Contact Sensia Technical Support for assistance.

**Table 5.1—Calculated Configuration Parameters**

	Parameter	Description	Calculated Input Value
Hardware Configuration	R Cable a	Cable resistance (In phase A direction for asymmetrical cables)	Calculated by Sensia using customer motor data shown in <a href="#">Table 2.6</a>
	R Cable b	Cable resistance (Orthogonal to phase A direction for asymmetrical cables)	
	R Stator	Motor stator resistance	
	R Iron Loss	Equivalent motor iron loss resistance	
	R Rotor	Motor rotor resistance (as seen from stator)	
	L Cable a	Cable inductance (in phase A direction for asymmetrical cable)	
	L Cable b	Cable inductance (orthogonal to phase A direction for asymmetrical cable)	
	L Stator Leakage	Motor stator leakage inductance	
	L Magnetization	Motor magnetization inductance	
	L Rotor Leakage	Motor rotor leakage inductance	
Mechanical Properties	Rotor Engagement Length	Total rotor/stator gap length	Calculated by Sensia using customer motor data shown in <a href="#">Table 2.6</a>
	Rotor Radius	Rotor outer radius	
	Stator Inner Radius	Stator inner radius	
	REDA Oil Number	Oil number (used for viscosity)	
	Rotor Bars	Number of rotor bars in motor	
Scaling Information	Voltage Scaling Factor	Voltage sensor attenuator step down ratio	Calculated by Sensia using customer motor data shown in <a href="#">Table 2.6</a>
	Current Scaling Factor	Current sensor current to voltage (ADC) ratio	

c. Click on the Update Deployment File button to proceed.

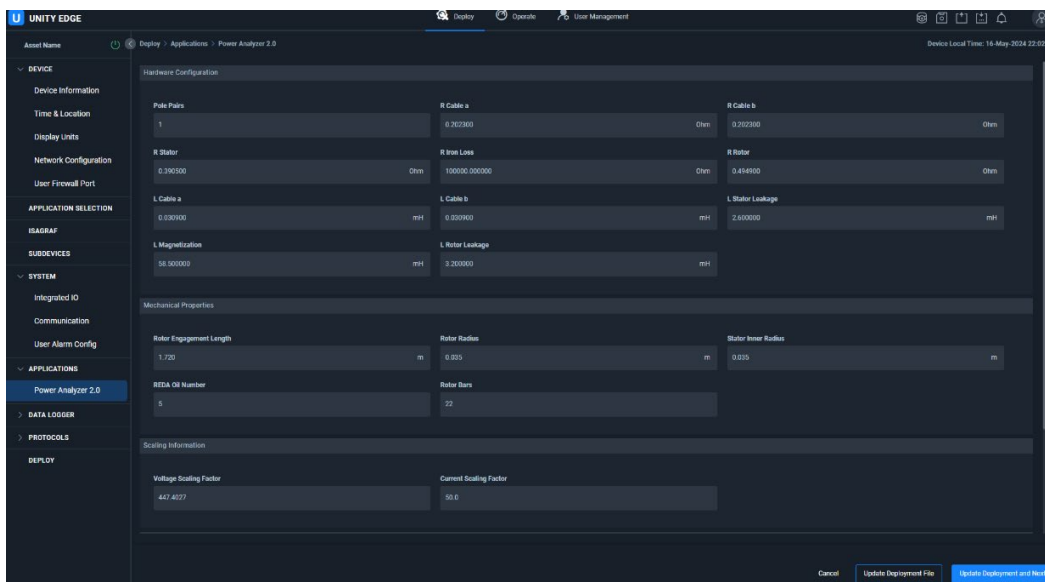

5. Configure internet connectivity.
  - a. Select Device>Network Configuration in the navigation tree.
  - b. Verify the Internet Selection is set to Cellular.

**CAUTION**

If the Internet Selection is NOT set to Cellular, DO NOT CHANGE THE SELECTION. You must contact Sensia Technical Support for proper configuration settings. Changing this setting to Cellular without contacting Sensia will not resume cellular connectivity.

- c. For internet configuration details, see the [QRATE HCC2 Software User Manual](#).

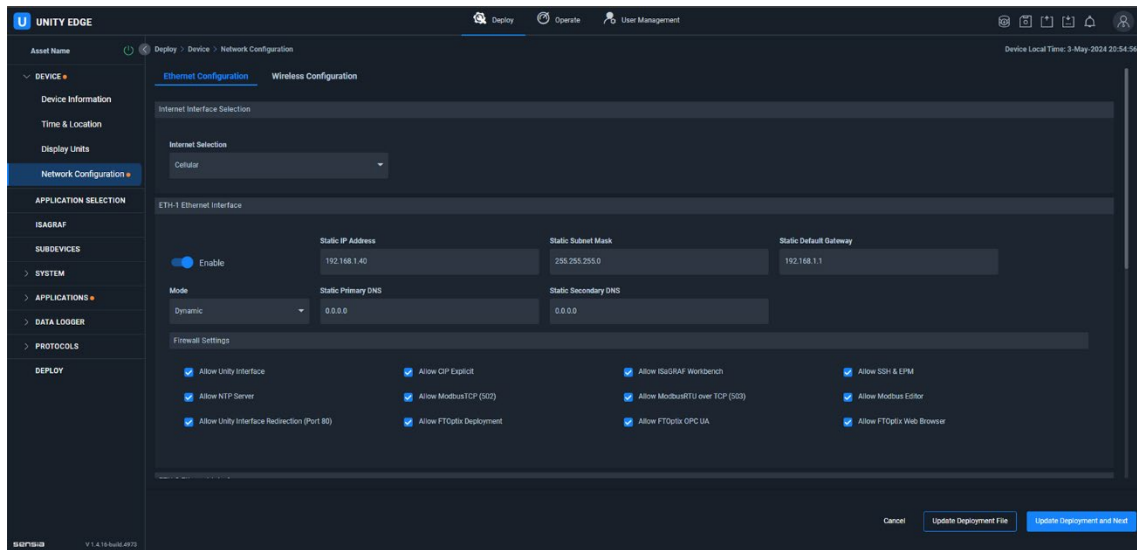

6. Deploy the configuration to the HCC2.
  - a. Select Deploy in the navigation tree and click the green Start button on the screen to initiate the update workflow.

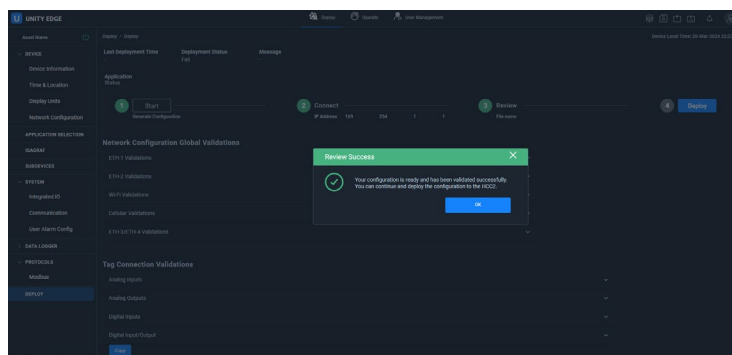

- b. When the Review Success confirmation screen appears, click OK.
  - c. Click the Deploy button on the right side of the screen.

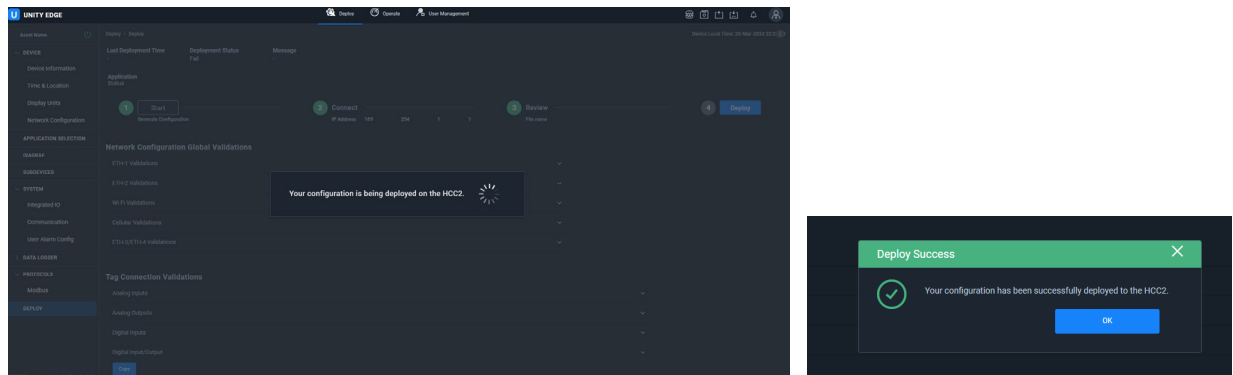

- d. When the Deploy Success confirmation message appears, click **OK**. Your PA2 application configuration is now complete.

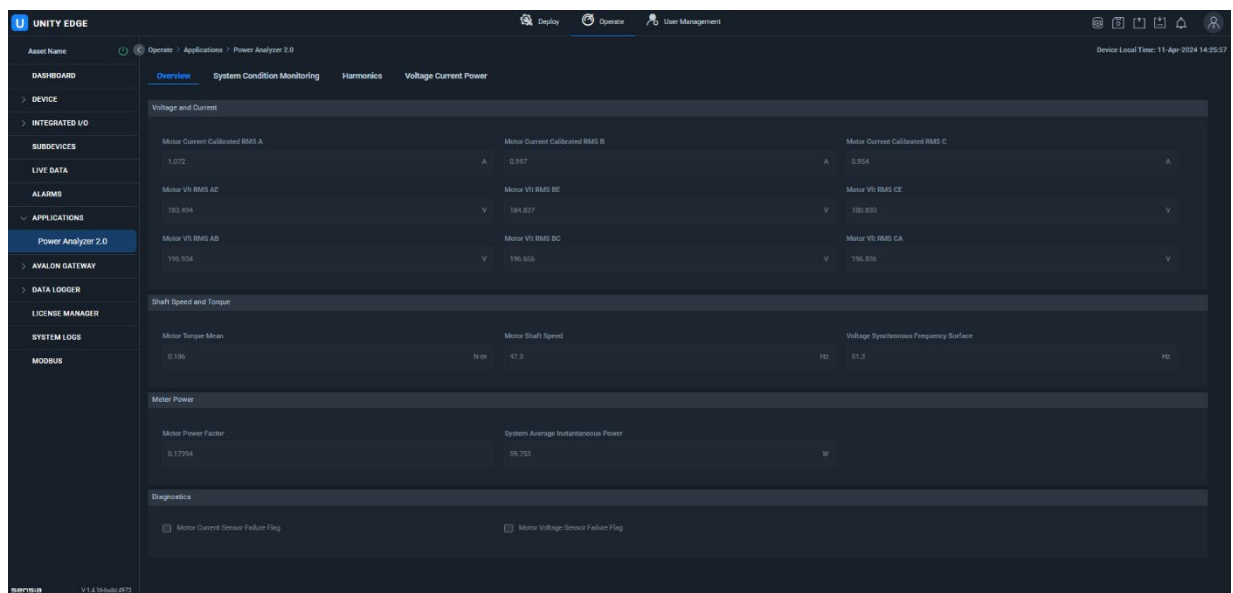

## 5.4 PROVISION THE HCC2 CONTROLLER

**Important** Your laptop must have internet access to complete this provisioning process.

To provision the HCC2 for communicating with Avalon,

1. Verify receipt of the hierarchy path for locating your Avalon asset (company name, field name, well name). This information is provided by Sensia.
2. In the Unity Edge navigation tree, select Avalon Gateway>CP Avalon Provisioning
3. Enter the URL for the production environment (sps.avalon.sensiadigital.io).
4. Click the blue **Provision** button.

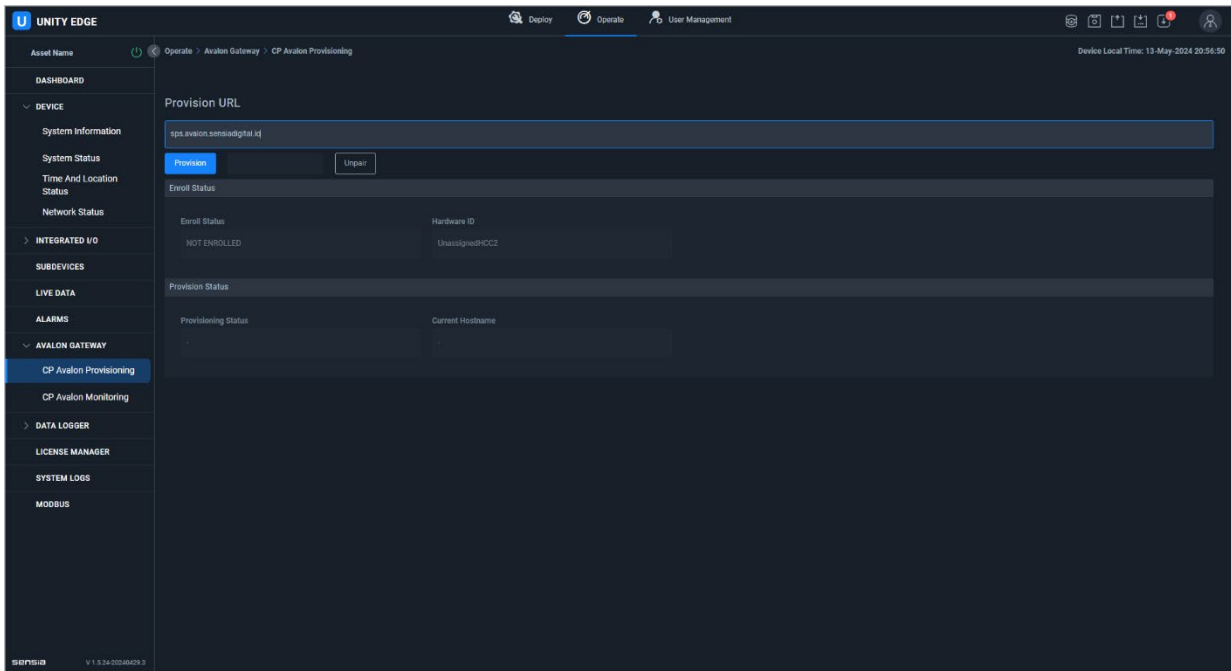

5. A URL confirmation message will appear. Click the X in the right corner to close the message.

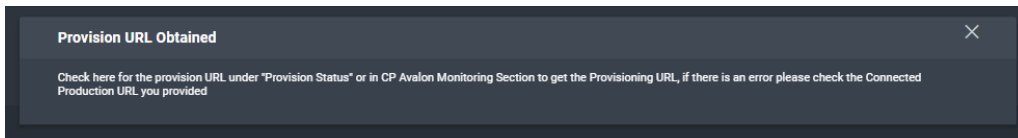

6. After a few seconds, the green provisioning link (Provision Link) will appear on the screen.

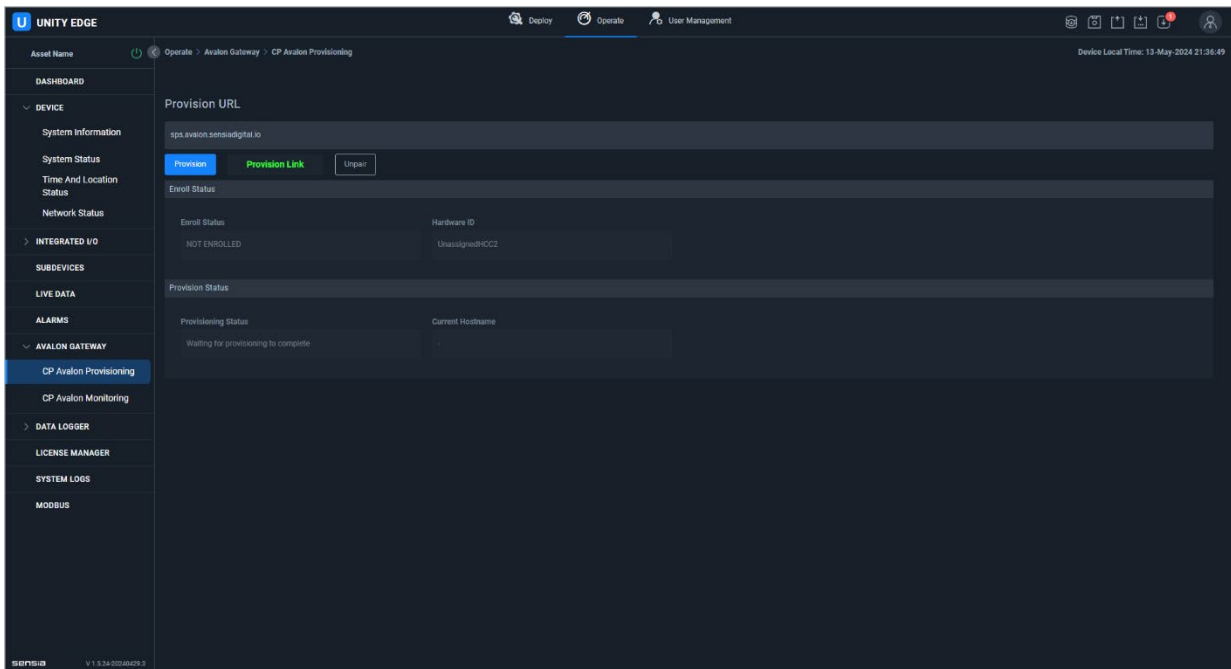

7. Click the Provision Link (green) to open an Avalon login dialog in the internet browser.
8. Enter your previously assigned credentials to log in.

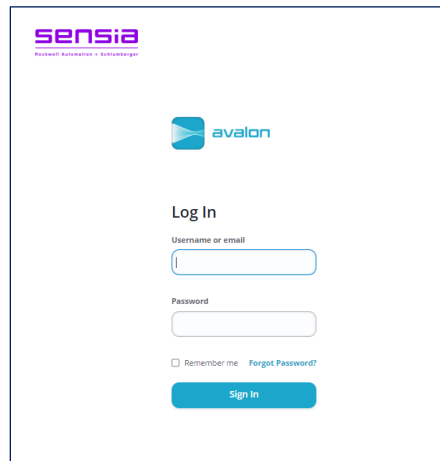

### 5.4.1 Pairing the Asset with the HCC2

You will complete the provisioning process by pairing your asset with the HCC2 in the Avalon interface.

Upon logging into Avalon, the first screen you will see is Pair Device with Data Provider.

1. Locate your asset using the hierarchy path provided by Sensia Technical Support (company name>field name>well name). In our example, the company name is HoustonLab, the field name is HCC2 PA2, and the well name is DP\_PA2.
2. Click on the well name to select the asset and click **Pair**.

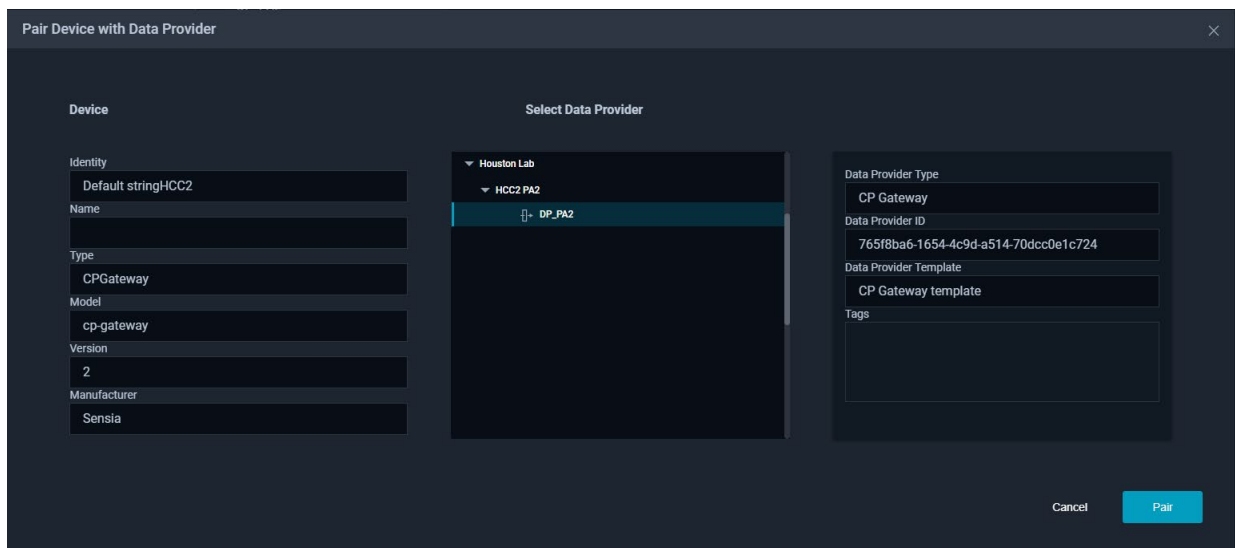

3. Click **OK** to acknowledge the Device Paired confirmation.

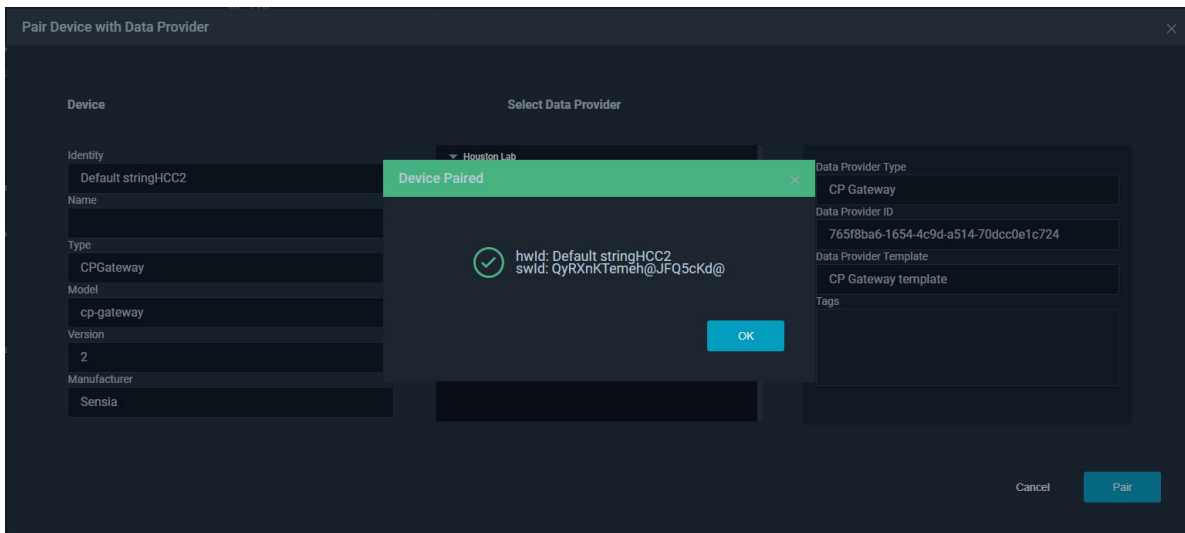

- When the Edit Data Provider screen appears, click **Save**.

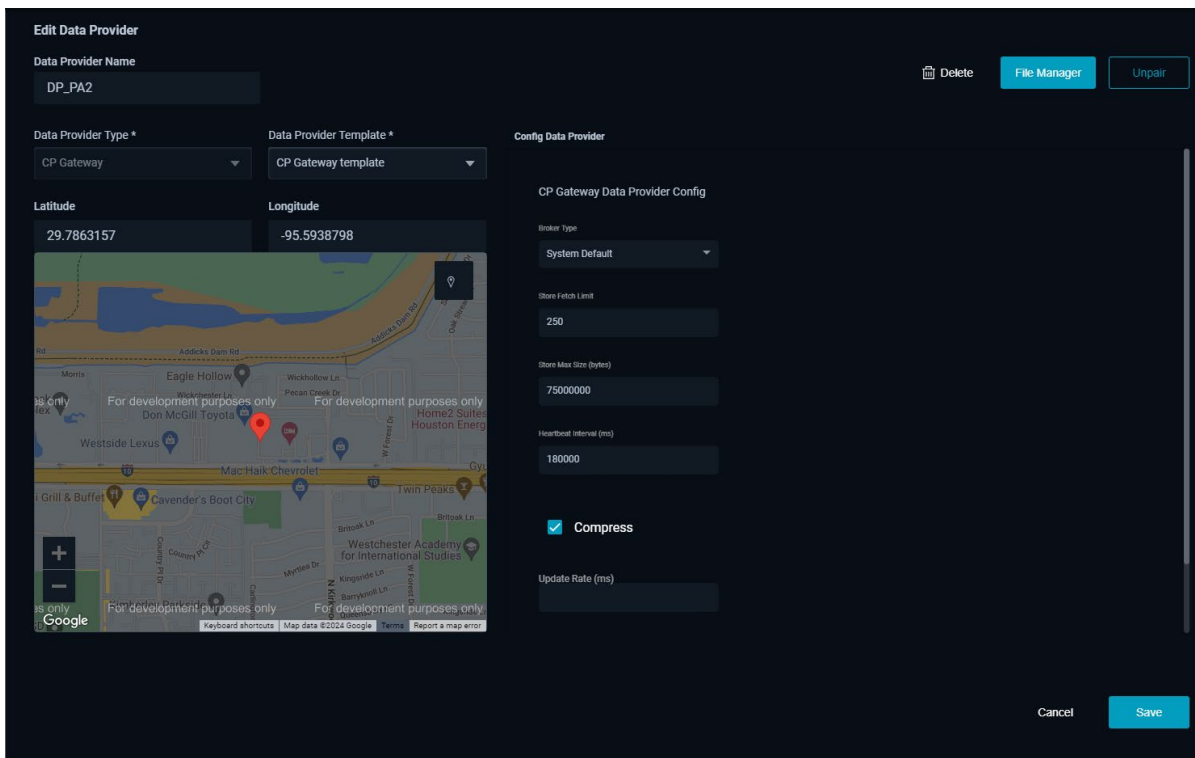

- Click OK to acknowledge the Data Provider confirmation message. You can now view the list of tags associated with your asset to verify Avalon connectivity.

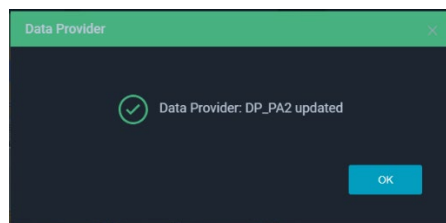

## 5.5 VERIFY AVALON CONNECTIVITY

With proper installation and configuration, the Power Analyzer 2.0 Application should now be streaming real-time and calculated data to Avalon.

This procedure assumes that the HCC2 PA2 application already has internet connectivity and has been provisioned with an asset created in Avalon.

To verify Avalon connectivity,

1. Log in to the Avalon software (if not already logged in).
2. Click the navigation tree icon in the upper left corner.
3. Locate your asset and verify that the green symbol is present to verify connectivity.

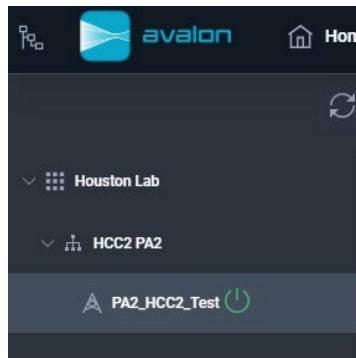

4. Click on your asset to display its tag list.
5. Observe the **Last Update** column values to verify that the tags are updating as expected.

The screenshot displays the 'Tag List' for the asset 'PA2\_HCC2\_Test'. The table below shows the data for various tags, with the 'Last Update' column highlighted by a red box. The 'Last Update' values are consistently 16-May-2024 16:37:58 or 16-May-2024 16:38:31.

Asset Name	Tag Name	Last Update	Value	RO/RW/M	Unit	Quality	Type
PA2_HCC2_Test	Motor Cable System Efficiency	16-May-2024 16:38:31	0.00	RO		Good	float
PA2_HCC2_Test	Motor Efficiency	16-May-2024 16:38:31	0.00	RO		Good	float
PA2_HCC2_Test	Motor Output Power	16-May-2024 16:38:31	0.00	RO	kW	Good	float
PA2_HCC2_Test	Motor Shaft Speed	16-May-2024 16:38:31	0.00	RO	Hz	Good	float
PA2_HCC2_Test	Motor Slip	16-May-2024 16:38:31	NaN	RO	%	Good	float
PA2_HCC2_Test	Motor Shaft Stability Indicator Magnitu	16-May-2024 16:38:24	NaN	RO		Good	float
PA2_HCC2_Test	Synchronous Frequency Surface	16-May-2024 16:38:24	0.00	RO	Hz	Good	float
PA2_HCC2_Test	Motor Torque Mean	16-May-2024 16:37:58	2.32e-3	RO	N·m	Good	float
PA2_HCC2_Test	Motor Voltage Negative Sequence	16-May-2024 16:37:58	0.20	RO	V	Good	float
PA2_HCC2_Test	Motor Voltage Positive Sequence	16-May-2024 16:37:58	0.23	RO	V	Good	float
PA2_HCC2_Test	Motor Voltage Zero Sequence	16-May-2024 16:37:58	16.50	RO	V	Good	float
PA2_HCC2_Test	Motor Voltage Zero Sequence Percent	16-May-2024 16:37:58	7.03427	RO	%	Good	float
PA2_HCC2_Test	Surface Apparent Power	16-May-2024 16:37:58	4.70e-4	RO	kW	Good	float
PA2_HCC2_Test	Surface Effective Power	16-May-2024 16:37:58	7.46e-5	RO	kW	Good	float

## 5.6 START-UP

When the well starts production, complete the following status checks to verify that:

- Data is updating in the local HMI.
- There are no Motor Current or Voltage failure flags (Alarms) in the local HMI or Unity Edge.
- Phasors are correct.
- Data is streaming in Avalon and matches the data shown in the local HMI and Unity Edge.

If you observe any issues, see [Section 9](#) for troubleshooting assistance.

## Section 6: Monitoring Data in Unity Edge

You can monitor pump and motor performance and equipment status via a series of Unity Edge dashboards. This section will examine the following dashboards and the parameters that can be observed within each:

- Overview
- System Condition Monitoring
- Harmonics
- Voltage, Current & Power

These parameters appear as tabs at the top of the Power Analyzer>Dashboards screen.

You can also monitor pump and motor performance and equipment status via the local HMI mounted in the door panel of the HCC2 cabinet or via the Avalon software interface. See [Section 7](#) and [Section 8](#) for more information.

### 6.1.1 Overview Dashboard

The Overview dashboard is the main PA2 application screen and provides

- an overview of the PA2 engine including data measured from the phases and diagnostics of the sensors
- a summary of outputs or calculated data generated by the algorithms embedded within the PA2 engine

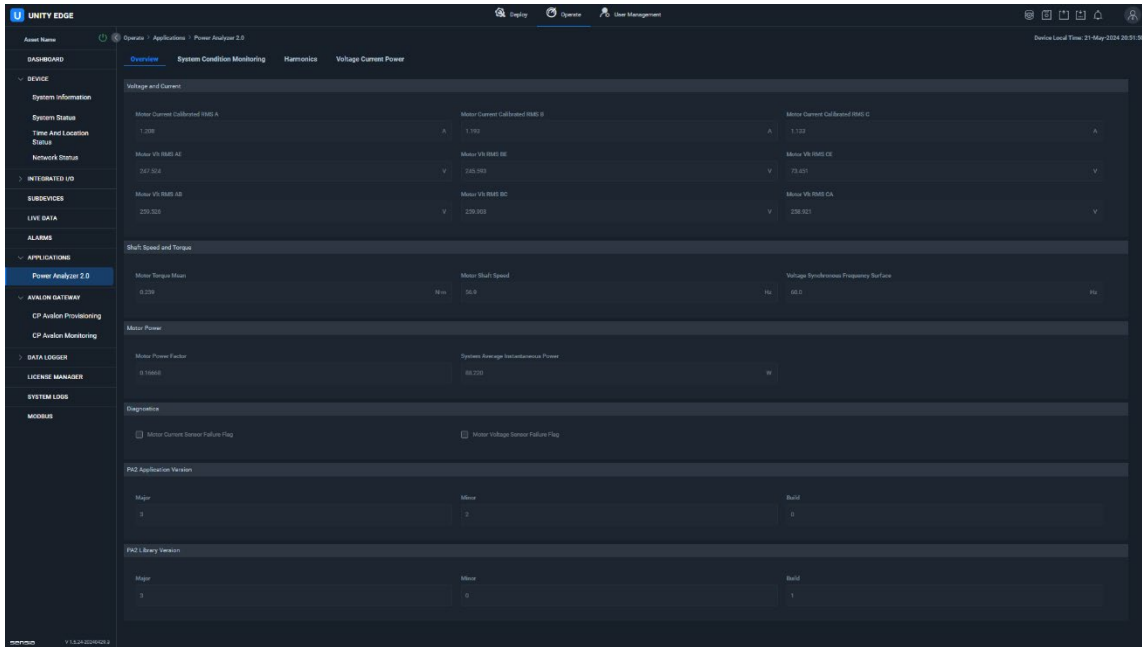
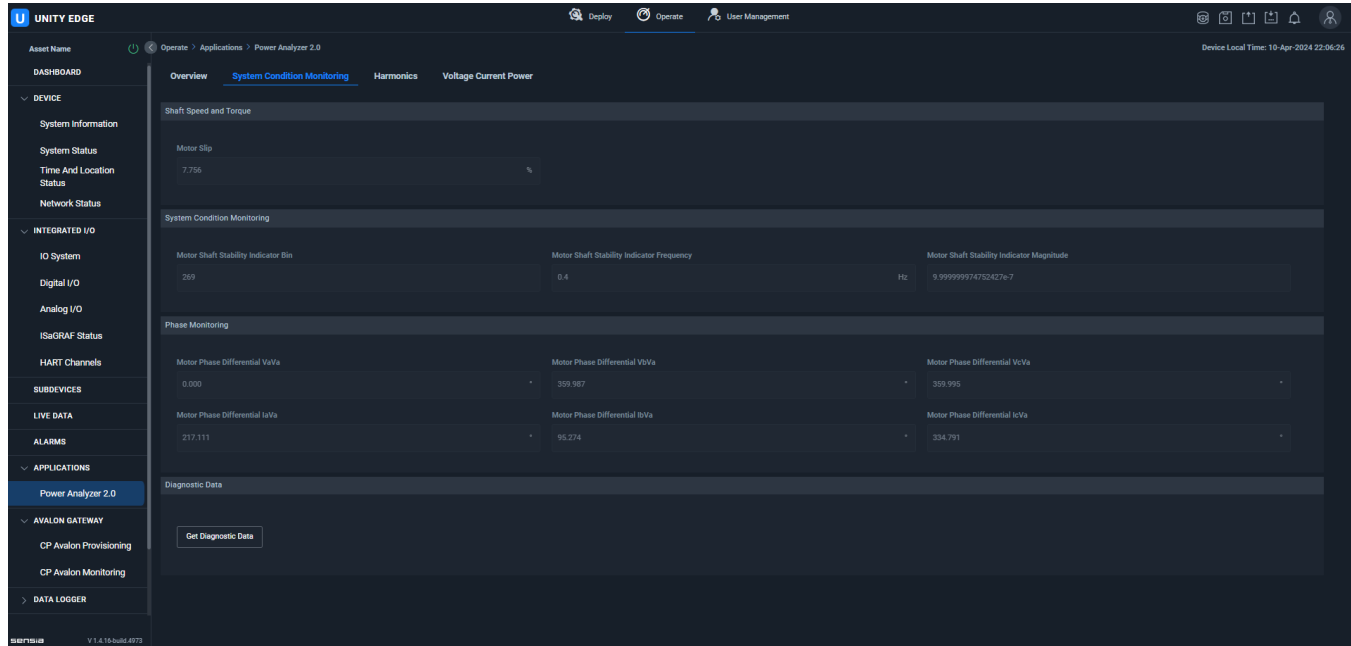

**Table 6.1—Overview**

	Parameter	Description
Voltage and Current	Motor Current Calibrated RMS A	Phase A root mean square current
	Motor Current Calibrated RMS B	Phase B root mean square current
	Motor Current Calibrated RMS C	Phase C root mean square current
	Motor VIt RMS AE	Voltage RMS relative to ground
	Motor VIt RMS BE	Voltage RMS relative to ground
	Motor VIt RMS CE	Voltage RMS relative to ground
	Motor VIt RMS AB	Phase to phase RMS voltage AB
	Motor VIt RMS BC	Phase to phase RMS voltage BC
	Motor VIt RMS CA	Phase to phase RMS voltage CA
Shaft Speed and Torque	Motor Torque Mean	Estimated motor torque
	Motor Shaft Speed	Estimated motor output speed
	Voltage Synchronous Frequency Surface	Fundamental drive frequency
Motor Power	Motor Power Factor	Power factor at motor terminals
	System Average Instantaneous Power	System average instantaneous power
Diagnostics	Motor Current Sensor Failure Flag	Detection of incorrect wiring - set when one channel has complete mismatch to other channels
	Motor Voltage Sensor Failure Flag	Detection of incorrect wiring - set when one channel has complete mismatch to other channels
PA2 Application Version	Major, Minor, and Build	PA2 application version
PA2 Library Version	Major, Minor, and Build	PA2 library version

## 6.1.2 System Condition Monitoring

Click the System Condition Monitoring tab to view system condition data related to the motor shaft. This data is generated by the PA2 Calculation engine and presented in four sections of the screen as shown below.

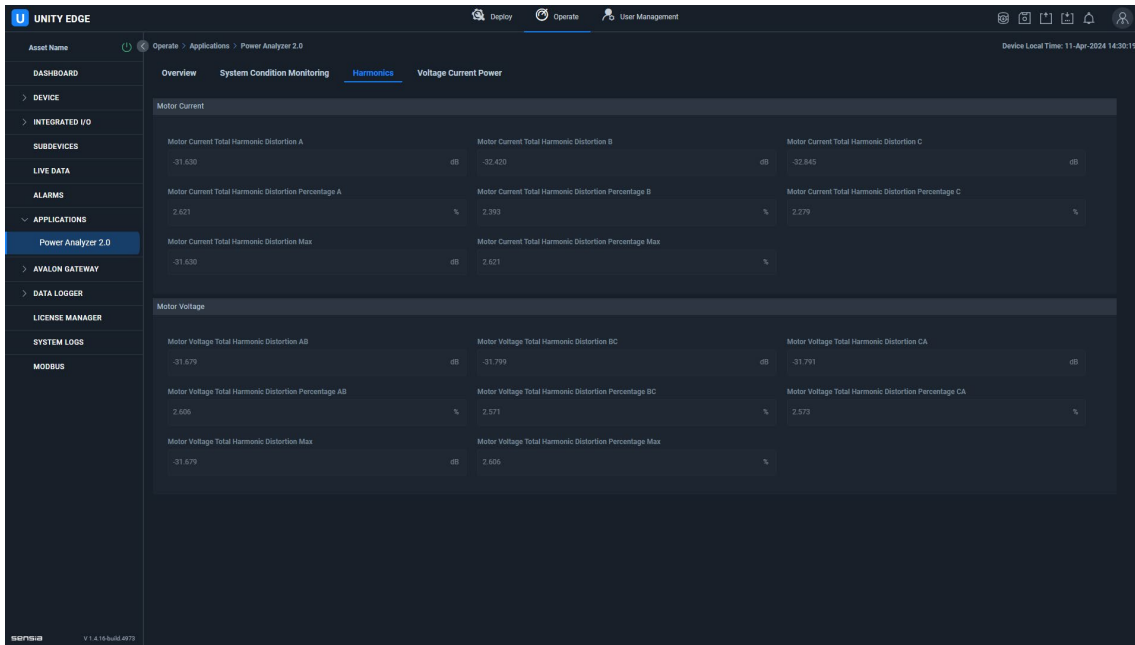

**Table 6.2— System Condition Monitoring**

	Parameter	Description
Shaft Speed and Torque	Motor Slip	Precision estimate of slip
System Condition Monitoring	Motor Shaft Stability Indicator Bin	Shows bin number of highest vibration tone (internal use only)
	Motor Shaft Stability Indicator Frequency	Shows frequency of largest vibration tone (typical subharmonic) – for internal use only
	Motor Shaft Stability Indicator Magnitude	Magnitude of largest vibration tone
Phase Monitoring	Motor Phase Differential VaVa	Lag between voltage phase A and voltage phase A
	Motor Phase Differential VbVa	Lag between voltage phase B and voltage phase A
	Motor Phase Differential VcVa	Lag between voltage phase C and voltage phase A
	Motor Phase Differential IaVa	Lag between current phase A and voltage phase A
	Motor Phase Differential IbVa	Lag between current phase B and voltage phase A
	Motor Phase Differential IcVa	Lag between current phase C and voltage phase A
Diagnostic Data	For internal use only	—

## 6.1.3 Harmonics

Click the Harmonics tab to view Power Quality Meter (PQM) data like Motor Current and Voltage Total Harmonic Distortions (THD), which can help identify sources of distortions in the pump. This data is generated by the PA2 Calculation engine and presented as two sections of the screen—Motor Current and Motor Voltage—as shown below.



**Table 6.3—Harmonics**

	Parameter	Description
Motor Current	Motor Current Total Harmonic Distortion A	Performance phase A [dB] of operation (high in case of high flux current)
	Motor Current Total Harmonic Distortion B	Performance phase B [dB] of operation (high in case of high flux current)
	Motor Current Total Harmonic Distortion C	Performance phase C [dB] of operation (high in case of high flux current)
	Motor Current Total Harmonic Distortion Percentage A	Total Harmonic Distortion in %
	Motor Current Total Harmonic Distortion Percentage B	Total Harmonic Distortion in %
	Motor Current Total Harmonic Distortion Percentage C	Total Harmonic Distortion in %
	Motor Current Total Harmonic Distortion Max	Maximum current THD of 3 phases
	Motor Current Total Harmonic Distortion Percentage Max	Maximum current Total Harmonic Distortion of 3 phases in %
Motor Voltage	Motor Voltage Total Harmonic Distortion AB	Phase to phase voltage
	Motor Voltage Total Harmonic Distortion BC	Phase to phase voltage
	Motor Voltage Total Harmonic Distortion CA	Phase to phase voltage
	Motor Voltage Total Harmonic Distortion Percentage AB	Phase to phase distortion (asymmetry indicates phase degradation)
	Motor Voltage Total Harmonic Distortion Percentage BC	Phase to phase distortion (asymmetry indicates phase degradation)
	Motor Voltage Total Harmonic Distortion Percentage CA	Phase to phase distortion (asymmetry indicates phase degradation)
	Motor Voltage Total Harmonic Distortion Max	Maximum voltage Total Harmonic Distortion of 3 phases
	Motor Voltage Total Harmonic Distortion Percentage Max	Maximum voltage Total Harmonic Distortion of 3 phases in %

### 6.1.4 Voltage Current Power

Click the Voltage Current Power tab to view data for current, voltage, and power. The PA2 calculation engine provides a dashboard with all the measured inputs as well as the calculated data for all the phases.

Motor Current		
Motor Current Calibrated RMS A	1.070 A	Motor Current Calibrated RMS B
		0.991 A
		Motor Current Calibrated RMS C
		0.945 A
Motor Current Peak To Peak A	2.991 A	Motor Current Peak To Peak B
		2.953 A
		Motor Current Peak To Peak C
		2.823 A
Motor Current Positive Sequence	1.372 A	Motor Current Negative Sequence
		0.031 A
		Motor Current Negative Percentage
		2.271 %
Motor Current Zero Sequence	0.050 A	Motor Current Zero Sequence Percentage
		4.402 %
Motor Voltage		
Motor Voltage RMS AB	196.763 V	Motor Voltage RMS BC
		196.565 V
		Motor Voltage RMS CA
		196.982 V
Motor Voltage Peak To Peak AB	668.624 V	Motor Voltage Peak To Peak BC
		661.729 V
		Motor Voltage Peak To Peak CA
		663.094 V
Motor Voltage RMS AE	184.176 V	Motor Voltage RMS BE
		181.354 V
		Motor Voltage RMS CE
		184.760 V
Motor Voltage Peak To Peak AE	734.640 V	Motor Voltage Peak To Peak BE
		746.860 V
		Motor Voltage Peak To Peak CE
		751.844 V
Motor Voltage Positive Sequence	149.473 V	Motor Voltage Negative Sequence
		0.108 V
		Motor Voltage Negative Sequence Percentage
		0.072 %
Motor Voltage Zero Sequence	203.679 V	Motor Voltage Zero Sequence Percentage
		136.264 %
Motor Power		
System Apparent Power	344.396 VA	Motor Output Power
		47.542 W
System Efficiency	0.81121	Motor Efficiency
		0.81991

**Table 6.4— Motor Current, Motor Voltage, and Motor Power**

	Parameter	Description
Motor Current	Motor Current Calibrated RMS A	Operational current amplitude RMS
	Motor Current Calibrated RMS B	Operational current amplitude RMS
	Motor Current Calibrated RMS C	Operational current amplitude RMS
	Motor Current Peak To Peak A	Peak amplitude
	Motor Current Peak To Peak B	Peak amplitude
	Motor Current Peak To Peak C	Peak amplitude
	Motor Current Positive Sequence	Effective current contributing to torque
	Motor Current Negative Sequence	Contributes to vibration, indicates asymmetry or two-point leakage
	Motor Current Negative Percentage	Relative imbalance current to positive sequence
	Motor Current Zero Sequence	Large currents indicate sensor failure
	Motor Current Zero Sequence Percentage	Amplitude relative to positive sequence

Motor Voltage	Motor Voltage RMS AB	Voltage relative to armor
	Motor Voltage RMS BC	Voltage relative to armor
	Motor Current RMS CA	Voltage relative to armor
	Motor Voltage Peak To Peak AB	Phase to phase peak value
	Motor Voltage Peak To Peak BC	Phase to phase peak value
	Motor Voltage Peak To Peak CA	Phase to phase peak value
	Motor Voltage RMS AE	Phase to phase voltage
	Motor Voltage RMS BE	Phase to phase voltage
	Motor Current RMS CE	Phase to phase voltage
	Motor Voltage Peak To Peak AE	Peak amplitude relative to armor
	Motor Voltage Peak To Peak BE	Peak amplitude relative to armor
	Motor Voltage Peak To Peak CE	Peak amplitude relative to armor
	Motor Voltage Positive Sequence	Voltage vector magnitude at intended drive frequency
	Motor Voltage Negative Sequence	Voltage vector magnitude at unintended negative drive frequency
	Motor Voltage Negative Sequence Percentage	Drive voltage quality
	Motor Voltage Zero Sequence	Quantifies leakage, AC symmetry to armor
Motor Voltage Zero Sequence Percentage	AC asymmetry relative to positive sequence voltage	
Motor Power	System Apparent Power	Drive apparent power
	Motor Output Power	Estimated motor mechanical output power
	Motor Efficiency	Mechanical motor output power/ electrical motor input power
	Motor-Cable System Efficiency	Mechanical output power/ drive output power (as measured at output of step-up transformer)

## Section 7: Monitoring Data via the Local HMI

A local HMI is mounted in the door of the HCC2 cabinet for monitoring the Power Analyzer 2.0 application at the wellsite.

This section steps you through the basic navigation of the HMI and provides examples of HMI screens.

From the HMI, you can monitor PA2 parameter live current and voltage measurements and calculated inputs for analyzing motor performance. You can also read system data to verify that the system is working as intended and verify the transmission of PA2 signals and power between the PA2 PowerDAQ and the HCC2 controller.

The PA2 monitoring information presented on HMI screens is essentially the same as that displayed in Unity Edge.

Unlike Unity Edge, the HMI allows you to

- view data in a tabular or gauge display
- view data in trends and charts. Waveform, phasor, and trend views are all supported.
- monitor data only (no configuration changes are supported in the HMI)

For information on making PA2 configuration changes, see [section 5.3](#).

### 7.1 NAVIGATING THE HMI

#### 7.1.1 Home Screen

By default, the first screen to appear in the HMI is the home screen, otherwise known as the HCC2 Core Systems Dashboard ([Figure 7.1](#)).

The information displayed is not specific to the Power Analyzer 2.0 application but may help you to troubleshoot system health issues affecting the display of PA2 parameters. Information for accessing PA2 screens is provided in [section 7.1.3](#).

To return to the home screen from any other HMI screen, press the Home button in the navigation bar described in the following subsection.

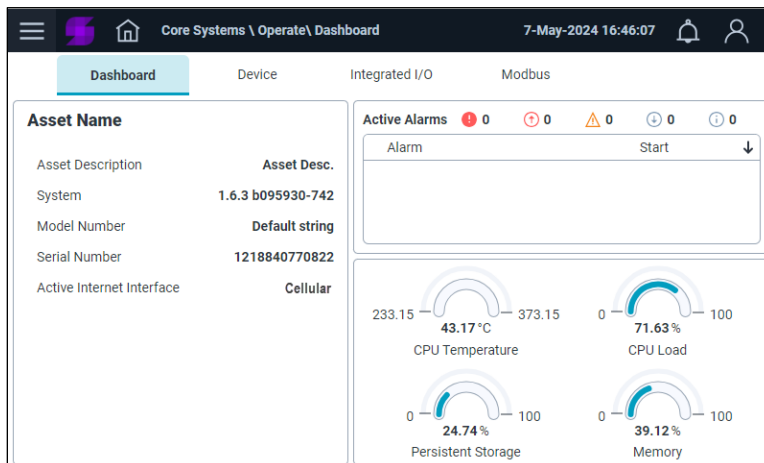

Figure 7.1: HMI Home Screen

Device and system information is presented in four tabs at the top of the home screen. Click these tabs to reveal submenus and more detailed status information. The screens shown below may be useful in troubleshooting PA2 issues involving network status, supply power, and analog inputs.

### Network Status

Core Systems \ Device \ Network Status 9-May-2024 23:10:33

Dashboard Device Integrated I/O Modbus

System Information System Status Time and Location **Network Status**

ETH-1 Ethernet Interface			
Enabled	Yes	Mode	Dynamic
Link Status/Connection State		Physical Up, Logical Up	
IP Address	10.80.250.142	Subnet Mask	255.255.252.0
Default Gateway		10.80.248.1	
Primary DNS	10.21.128.21	Secondary DNS	10.21.128.20
MAC		82:72:43:34:62:02	

ETH-2 Ethernet Interface			
Enabled	Yes	Mode	Static
Link Status/Connection State		Physical Down, Logical Up	
IP Address	192.168.1.41	Subnet Mask	255.255.255.0
Default Gateway			
Primary DNS		Secondary DNS	
MAC		36:D9:AA:14:9E:67	

ETH-3 Ethernet Interface			
Enabled	Yes	Link Status/Connection State	Eth3 Off, Eth4 Off
IP Address	192.168.1.33	Subnet Mask	255.255.255.0
Default Gateway		192.168.1.1	
Primary DNS	0.0.0.0	Secondary DNS	0.0.0.0
MAC			

<< < 1/2 > >>

### Supply Power Status

Core Systems \ Integrated I/O \ Supply Power 9-May-2024 23:10:23

Dashboard Device **Integrated I/O** Modbus

**Supply Power** Digital I/O Analog I/O ISaGRAF Status

Supply Power Status			
Power Input A Status	OK	Power Input B Status	Not OK
Supply Power Voltage	23.94 V	Supply Power Current	631 mA
Supply Power Wattage		15.106 W	

### Analog I/O Status

Core Systems \ Integrated I/O \ Analog Inputs 9-May-2024 23:10:23

Dashboard Device **Integrated I/O** Modbus



Supply Power Digital I/O **Analog I/O** ISaGRAF Status

Analog Inputs		Analog Outputs	
Analog Input 1	-0.01058	Analog Output 1	0 %
Analog Input 2	-0.00655	Analog Output 2	0 %
Analog Input 3	-0.00787		
Analog Input 4	0.06106		
Analog Input 5	0.0579		
Analog Input 6	0.03299		
Analog Input 7	0.00167		
Analog Input 8	-0.00006		

Figure 7.2: HMI Core Systems Screens

### 7.1.2 Top Navigation Bar

At the top of the HMI screen is a navigation bar. Here, you will find shortcut links for a variety of screens and menu selections to help you navigate the HMI with ease. Navigation bar links include:

- Hamburger icon – jump to the Main menu, where you can select the Power Analyzer 2.0 application
- Home button – jump to the dashboard for HCC2 Core Systems for system health monitoring
- Alarm icon – view a system alarm summary screen
  - The icon appears as an alarm symbol  if there are no active system alarms.
  - The icon appears as one of several severity symbols ( for example) when one or more active alarms exist in the system.
  - When active system alarms exist, the number of active alarms will appear in the navigation bar next to the alarm icon (Figure 7.3). These are not PA2 alarms but rather system alarms detected by the HCC2.

The navigation path of your active HMI screen and the current date and time (read from HCC2) are also displayed in the navigation bar.

**Note** The User Profile icon in the navigation bar is a placeholder for future use. There is no requirement for a password-protected user login to view PA2 data on the HMI.



**Figure 7.3—HMI navigation bar**

### 7.1.3 Main Menu

The main menu allows you to select any installed application such as Power Analyzer 2.0, and navigate data display categories where applicable. Click the Hamburger icon in the top navigation bar to open the main menu.

The PA2 application menu is presented in the figure below. Local HMI screens for PA2 are organized within two groups:

- Operate
- Trends and Charts



**Figure 7.4: HMI main menu**

Example screens for these two groups are provided in [sections 7.2](#) and [7.3](#).

### 7.1.4 Navigation Tabs

Within each group, a row of tabs allow you to select the data you desire. Tabs names will vary, depending on the group you select.

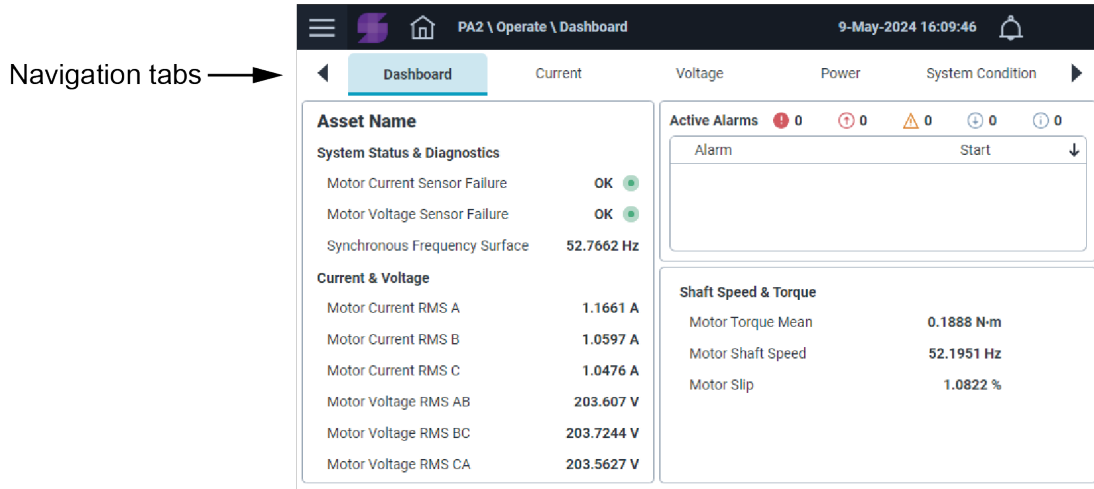

Figure 7.5: Navigation Tabs

### 7.1.5 Data Presentation Options

In the Operate screens, you can view most data in either a tabular or gauge display. You can switch between the views using the toggle control in the bottom right corner.

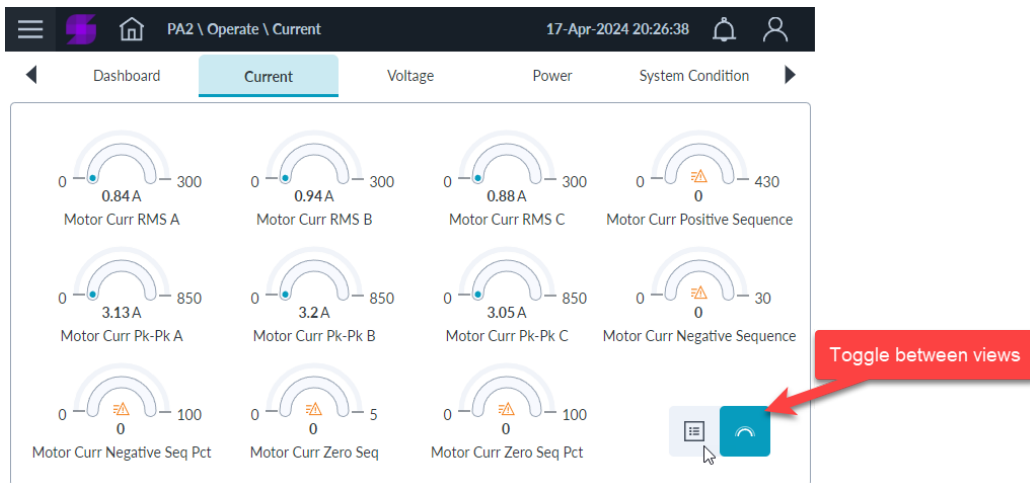

Figure 7.6: Toggle for switching views

### 7.1.6 Communications Failure

**Note** When a measurement parameter cannot be read, a caution icon will appear in the HMI screen. In tabular view, the icon will appear next to the parameter name. In gauge view, it will appear just below the gauge shape as shown.



## 7.2 OPERATE SCREENS

Below is a sample of Operate screens for viewing PA2 inputs and performance data. For a sample of Trends and Charts screens, see [section 7.3](#).

Descriptions for individual parameters are provided in [Section 6](#), as noted below.

### Dashboard

Summary of system status, alarm status, motor inputs, and motor performance indicators.

Diagnostic green and red indicators help you identify sensor failure. A green indicator signifies good sensor health, while a red indicator indicates a sensor fault.

For parameter definitions, see [section 6.1.1](#).

### Motor Current (Tabular)

This screen provides measured current inputs for each electrical phase and calculated data for analyzing motor performance.

For parameter definitions, see [section 6.1.4](#).

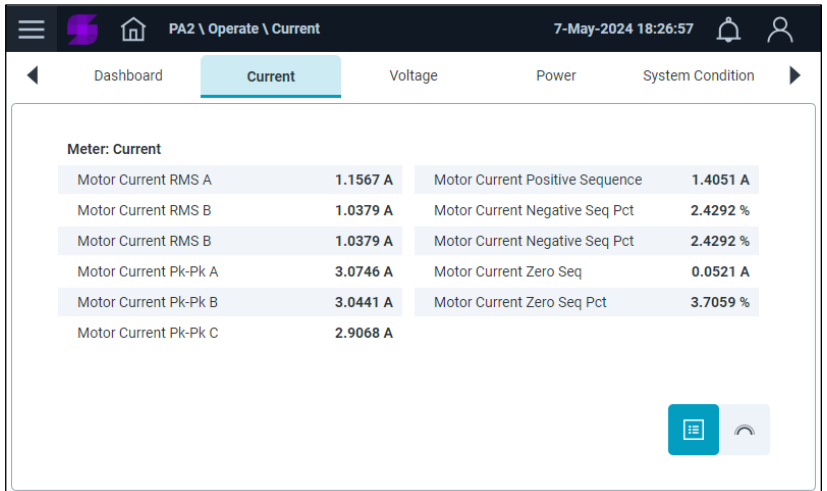
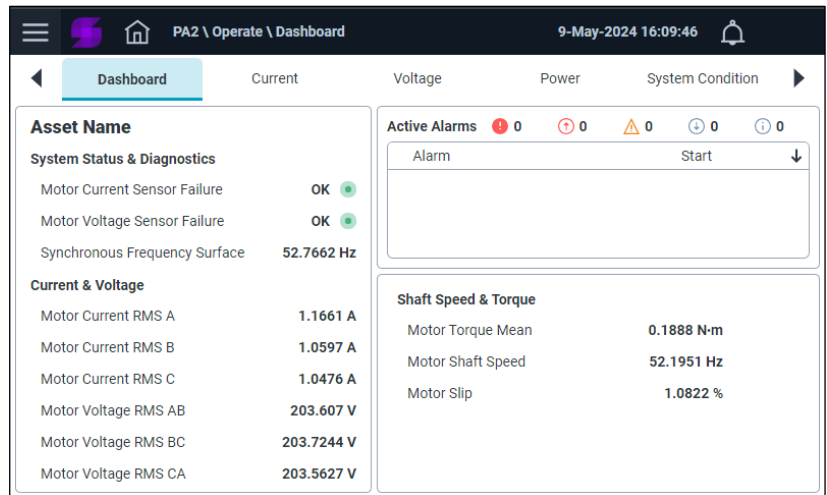

### Motor Current (Gauge)

This screen presents the current data described above in a gauge format.

For parameter definitions, see [section 6.1.4](#).

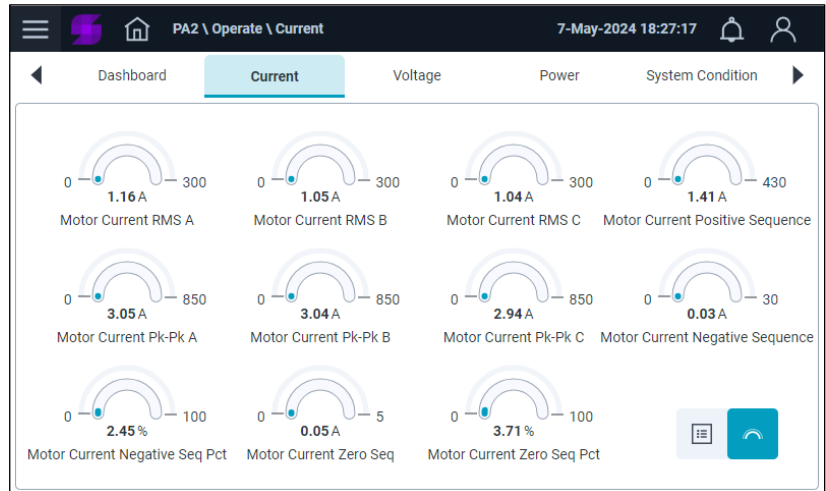

### Motor Voltage (Tabular)

This screen provides measured voltage inputs for each electrical phase and calculated data for analyzing motor performance.

For parameter definitions, see [section 6.1.4](#).

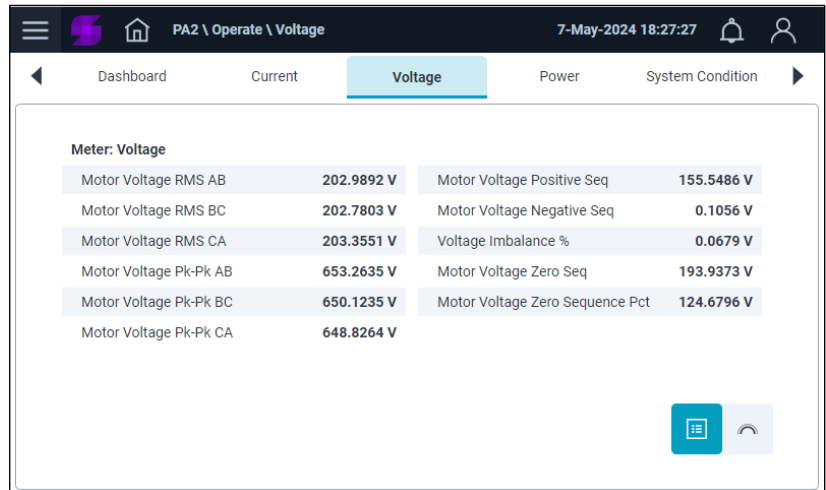

### Motor Voltage (Gauge)

This screen presents the voltage data described above in a gauge format.

For parameter definitions, see [section 6.1.4](#).

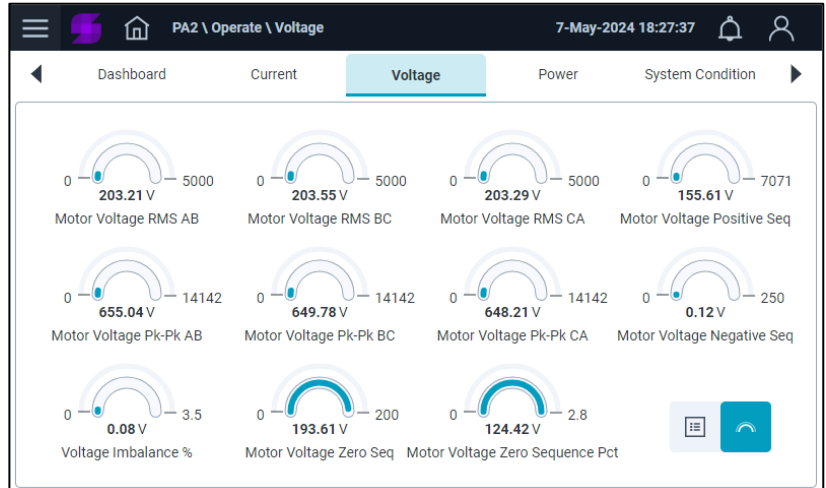

### Motor Power

Motor Power refers to the mechanical output power delivered by a motor to drive a load. It is a crucial parameter that determines the motor’s ability to perform useful work.

For parameter definitions, see [section 6.1.4](#).

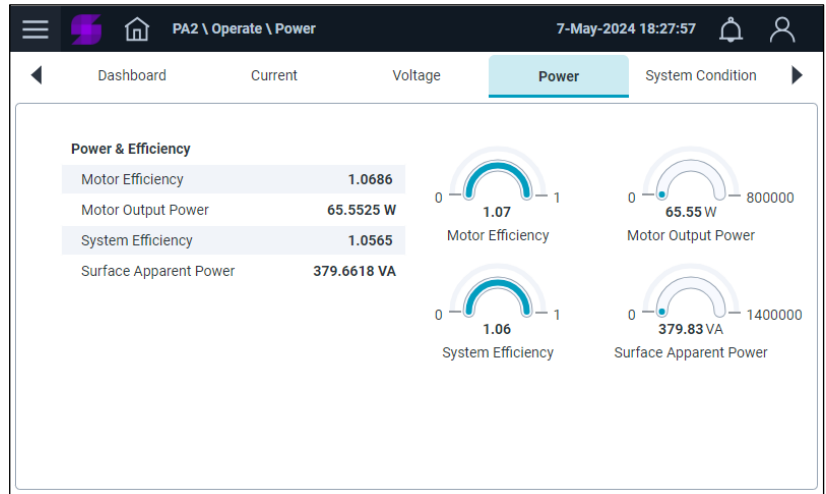

### System Condition (Tabular)

This screen presents calculated data regarding the motor shaft for performance analysis. Shaft speed and torque are inversely proportional to each other and refer to the rate at which the motor can rotate.

For parameter definitions, see [section 6.1.2](#).

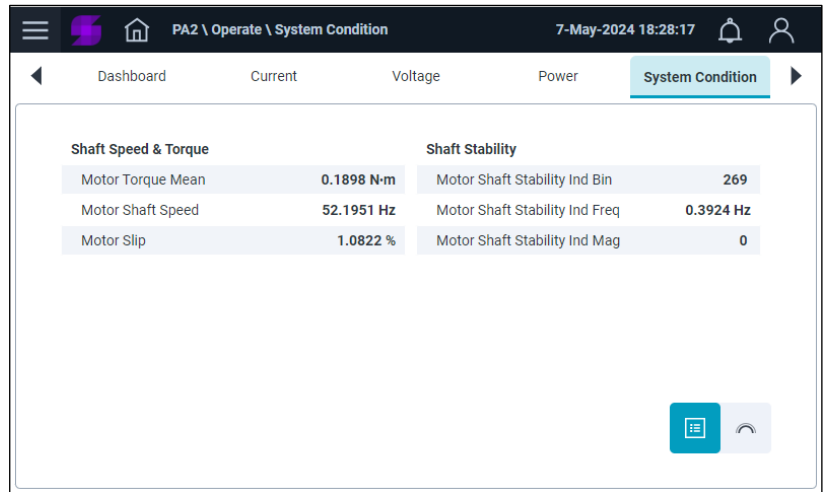

### System Condition (Gauge)

This screen presents calculated data regarding the motor shaft for performance analysis. Shaft speed and torque are inversely proportional to each other and refer to the rate at which the motor can rotate.

For parameter definitions, see [section 6.1.2](#).

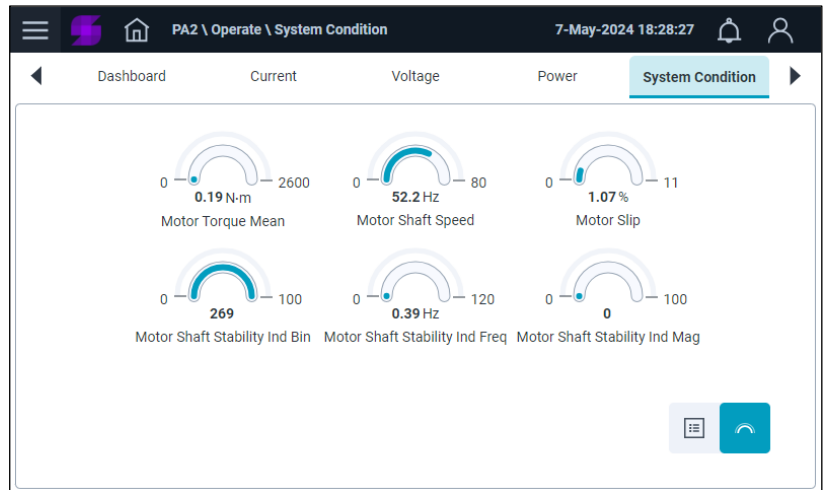

### Motor Current Harmonics (Tabular)

This data can help indicate sources of distortions in the pump for corrective action.

Click the right arrow at the bottom of the screen to switch from current to voltage views.

For parameter definitions, see [section 6.1.3](#).

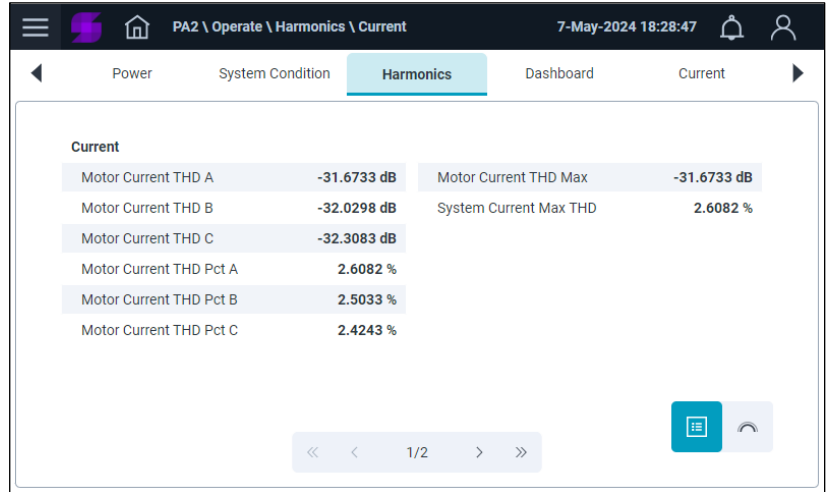

### Motor Current Harmonics (Gauge)

This data can help indicate sources of distortions in the pump for corrective action.

Click the right arrow at the bottom of the screen to switch from current to voltage views.

For parameter definitions, see [section 6.1.3](#).

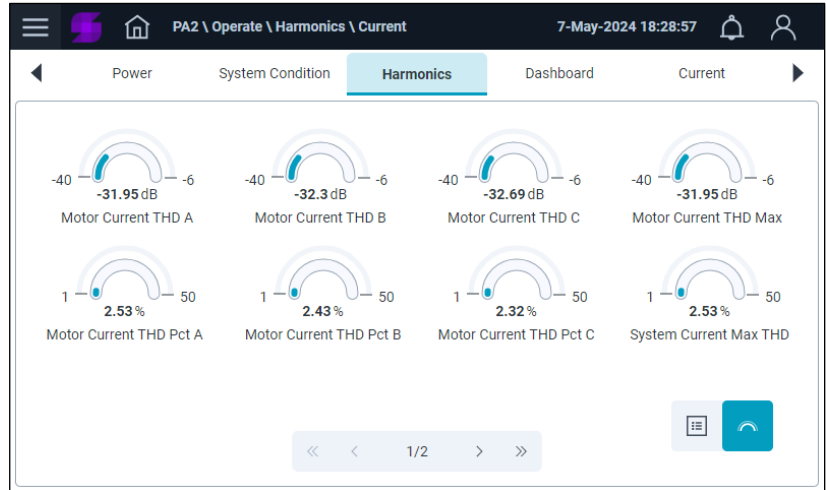

### Motor Voltage Harmonics (Tabular)

This data can help indicate sources of distortions in the pump for corrective action.

Click the left arrow at the bottom of the screen to switch from voltage to current views.

For parameter definitions, see [section 6.1.3](#).

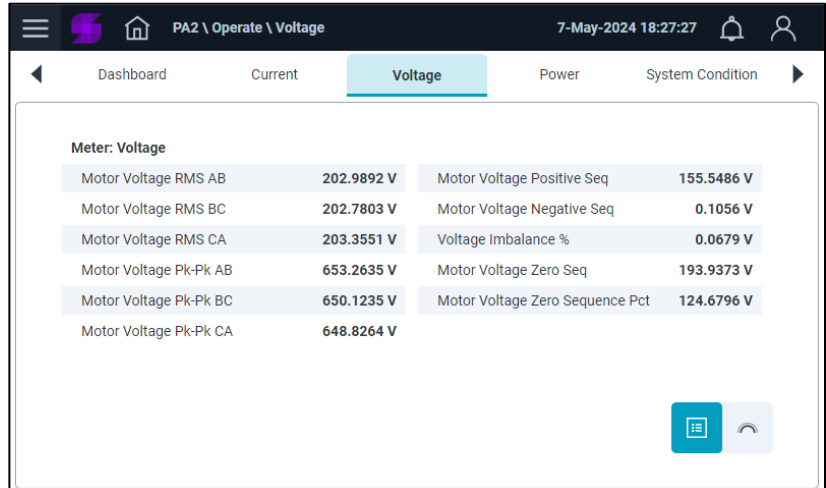

### Motor Voltage Harmonics (Gauge)

This data can help indicate sources of distortions in the pump for corrective action.

Click the left arrow at the bottom of the screen to switch from voltage to current views.

For parameter definitions, see [section 6.1.3](#).

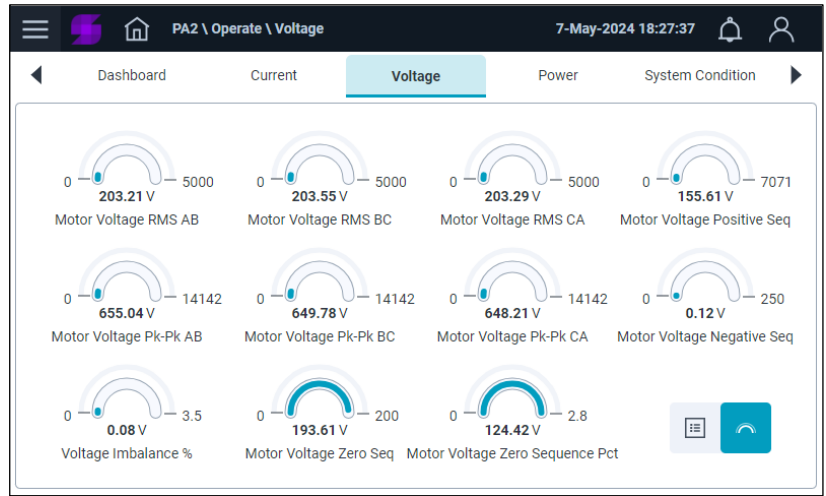

## 7.3 TRENDS AND CHARTS

The PA2 engine provides a set of parameters to plot the following trends and charts.

For a sample of Operate screens for viewing PA2 inputs and performance data, see [section 7.2](#).

Descriptions for individual parameters are provided in [Section 6](#), as noted below.

### Phasors

This screen presents current and voltage data in a phasor diagram to help analyze phase shifts, troubleshoot issues, optimize motor performance, detect incorrect wiring and phase issues, and ensure the reliable operation of an ESP system.

For parameter definitions, see [section 6.1.2](#).

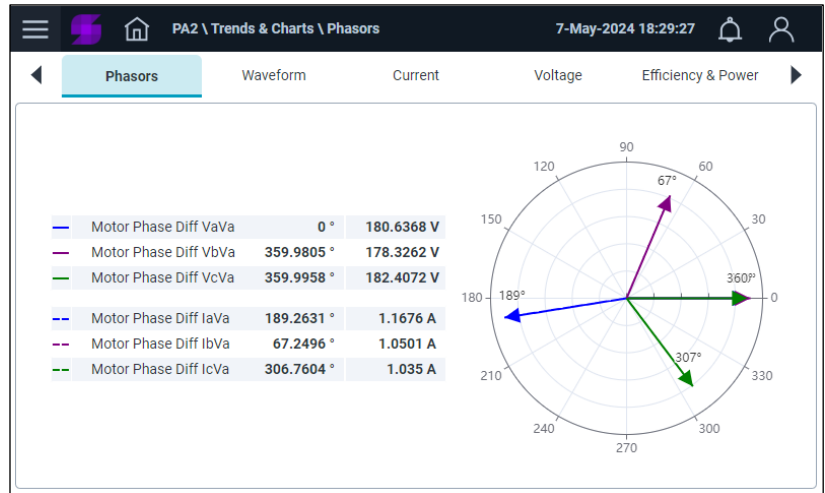

### Waveform

This screen presents data acquired from the PowerDAQ module to monitor current and voltage phases of the pump. The local HMI plots these data periodically and gives users an option to zoom in and out for accurate visualization and analysis.

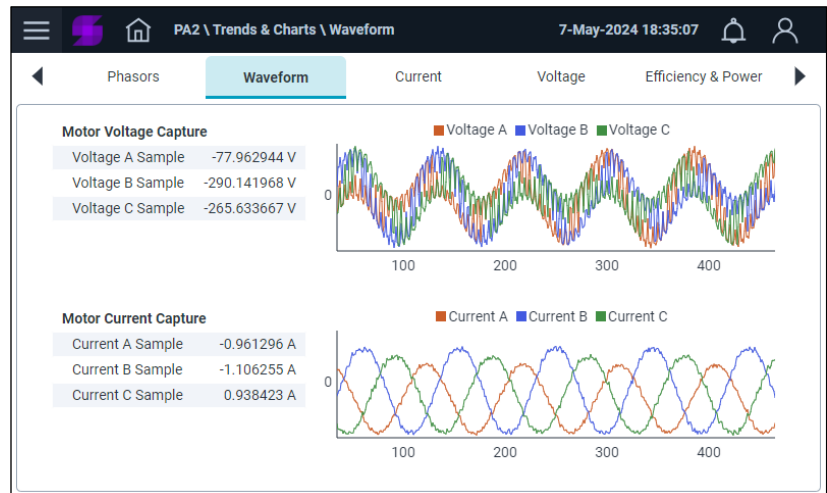

### Motor Current

This screen presents raw current readings from each electrical phase in intervals ranging from 15 minutes to 1 year.

For parameter definitions, see [section 6.1.4](#).

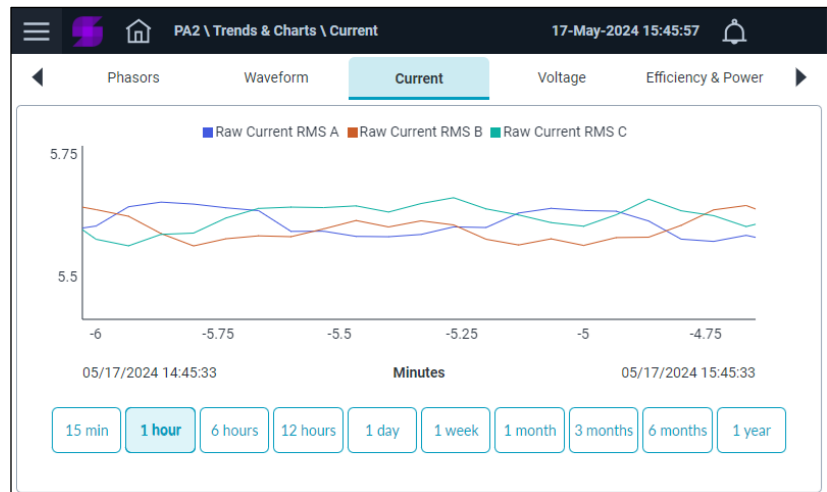

### Motor Voltage

This screen presents voltage readings from each electrical phase in intervals ranging from 15 minutes to 1 year.

For parameter definitions, see [section 6.1.4](#).

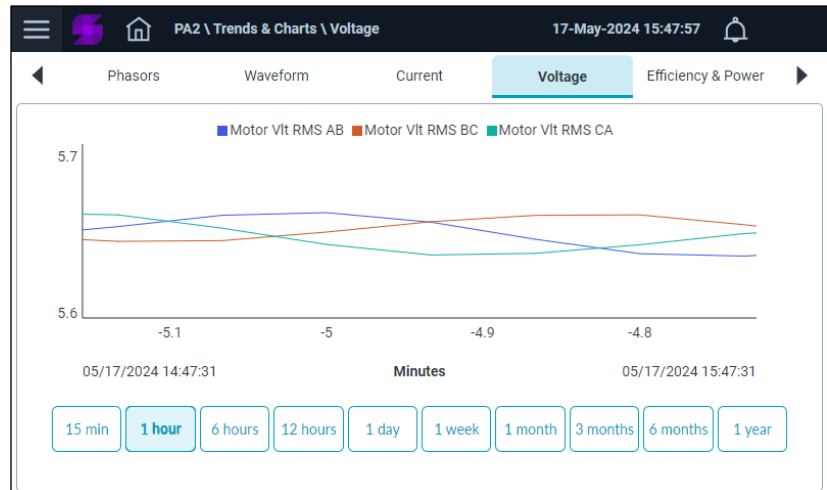

### Efficiency and Output Power

This screen presents efficiency and power data in intervals ranging from 15 minutes to 1 year.

For parameter definitions, see [section 6.1.4](#).

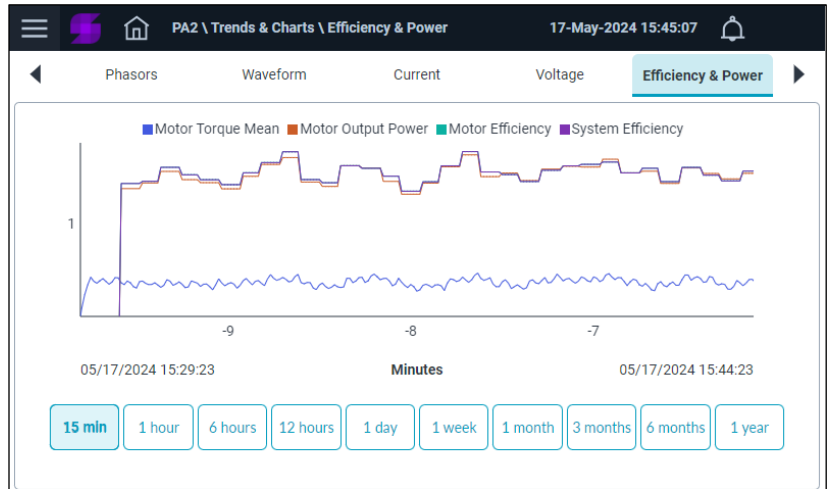

### Motor Speed

This screen presents motor speed data in intervals ranging from 15 minutes to 1 year.

For parameter definitions, see [section 6.1.1](#).

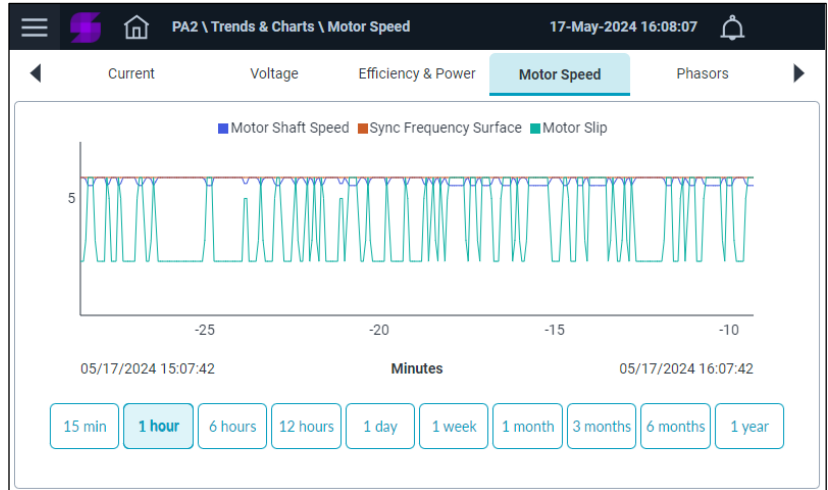

## Section 8: Monitoring Data in Avalon

Avalon is an important part of Sensia's Power Analyzer 2.0 end-to-end solution, allowing field engineers/technicians, SMEs, managers, and others to access and remotely monitor field operations.

Users can access real-time parameters, charts, and trends for analytics. Some of these tools and parameters are as follows:

### 8.1 LIFT SURVEILLANCE

Avalon Lift Surveillance, a collection of modules layered on top of the standard Avalon infrastructure, displays real-time data from the PA2 application in the following formats:

#### 8.1.1 General Overview

Avalon's general overview screen displays a variety of PA2 information including but not limited to the following:

- Customizable trend charts
- Latest updated transmission
- Pump status
- Updated phasor and waveform charts
- Alarms and events (configurable)
- List of all PA2 parameters sent to Avalon from the HCC2

Users can select from a variety of customized templates, based on the parameters being monitored and charted. For more information about Avalon, please refer to the Avalon user manual.

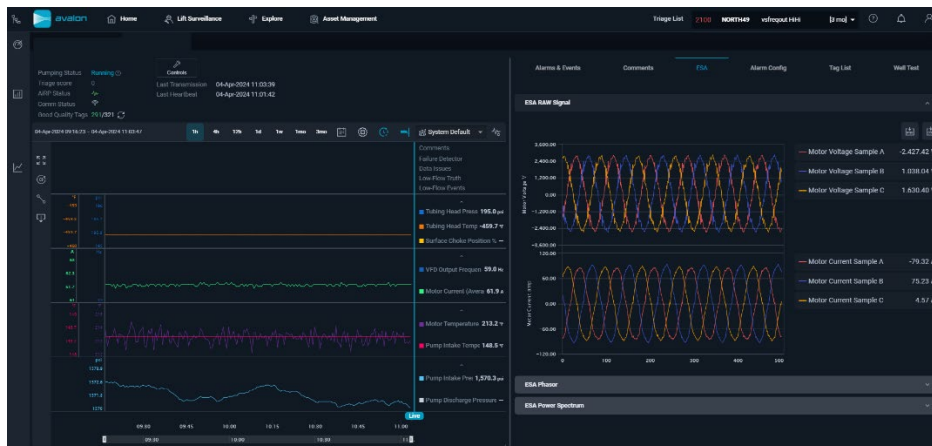

Figure 8.1—Avalon Overview screen

#### 8.1.2 Waveforms (Raw Signals)

Field engineers and SMEs can visualize the waveform in Avalon to analyze system performance, diagnose issues, and make decisions. The waveform provides detailed technical information such as voltage fluctuations, current levels, frequency, and phase relationships specific for ESP operations, allowing for comprehensive monitoring, analysis, and troubleshooting.

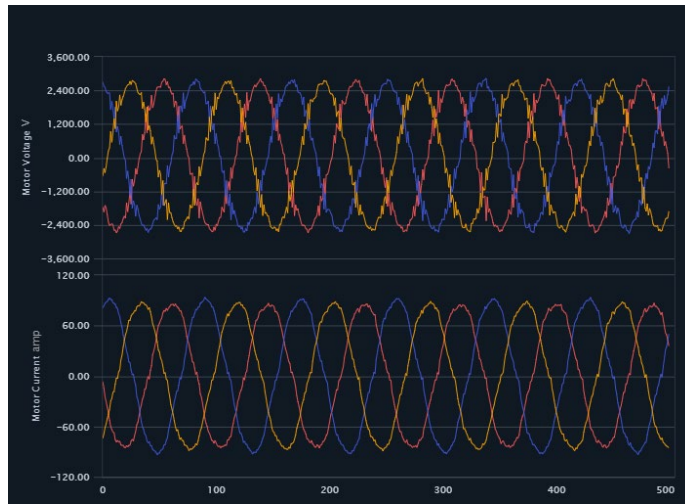

Figure 8.2—Avalon waveform display

### 8.1.3 Phasors

Using Avalon’s phasor chart or diagram, field engineers and SMEs can analyze the phase shift between voltage and current, troubleshoot issues, optimize motor performance, detect incorrect wiring and phase issues, and ensure the reliable operation of an ESP system.

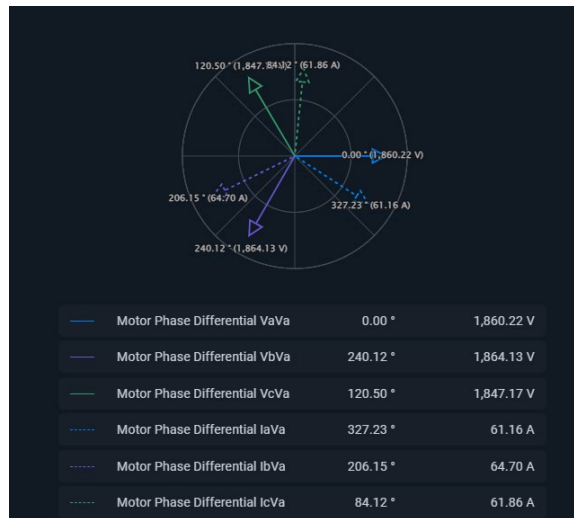

Figure 8.3—Avalon phasor diagram

### 8.1.4 Live Data (Tag List)

Avalon offers a comprehensive list of tags featuring real-time values of the complete system. This includes measured parameters, calculated data, and integration of VSD variables, surface instruments, downhole gauge, and other relevant data sources.

Tag Name	Last Update	Value	RO/RW/M	Unit	Quality
Asset Status	04-Apr-2024 13:17:54	Connected	RO		Good
Comm Status	04-Apr-2024 13:17:54	Connected	RO		Good
Local Time	04-Apr-2024 13:17:52	4-Apr-2024 18:17:52	RO		Good
Time Zone	04-Apr-2024 13:17:52	Coordinated Univers...	RO		Good
UTC	04-Apr-2024 13:17:52	4-Apr-2024 18:17:52	RO		Good
Motor Curr Negative Seq Pct	04-Apr-2024 13:17:51	2.96	RO	%	Good
Motor Curr Negative Sequence	04-Apr-2024 13:17:51	2.62	RO	A	Good
Motor Curr Positive Sequence	04-Apr-2024 13:17:51	88.36	RO	A	Good
Motor Curr Zero Seq	04-Apr-2024 13:17:51	0.26	RO	A	Good
Motor Curr Zero Seq Pct	04-Apr-2024 13:17:51	0.29	RO	%	Good
Motor Power Factor	04-Apr-2024 13:17:51	0.82	RO		Good
Motor Torque Mean	04-Apr-2024 13:17:51	652.05	RO	N-m	Good
Motor Vlt Negative Seq	04-Apr-2024 13:17:51	3.95	RO	V	Good

Figure 8.4—Avalon tags for PA2 parameters

### 8.1.5 Trends (Templates)

PA2 application users can create and access customized Avalon templates tailored to the parameters being monitored and trended for subsequent analysis by SMEs and field engineers.

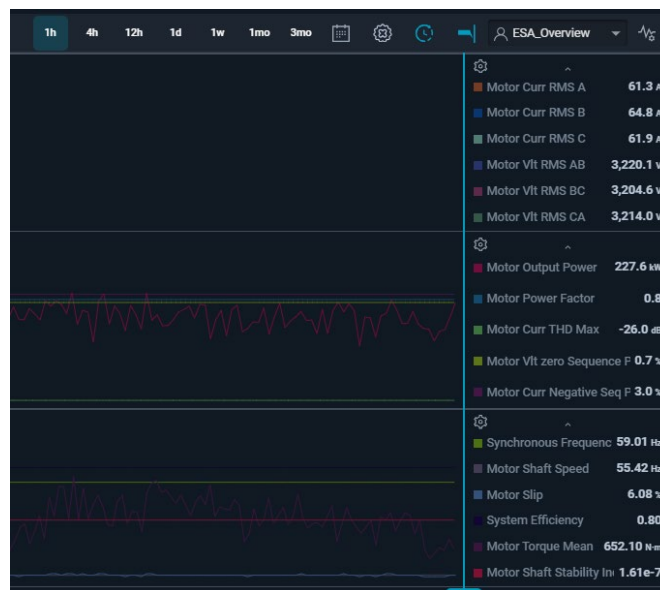

Figure 8.5—Avalon templates for customized data presentation

## Section 9: Troubleshooting

### 9.1 MECHANICAL/INSTALLATION TROUBLESHOOTING

This section addresses problems that could arise during the installation and commissioning of the packaged PA2 solution. For each case, steps are provided for resolving these issues.

#### 9.1.1 Failure to Power on the PA2 Controller

1. Check if the fuse in the AC power terminal of the HCC2 controller cabinet is blown. If the fuse is blown, replace it with [part number 9A-101155848](#).
2. Ensure that the fuse in the cabinet's power terminal is closed.
3. Verify that the power cables are correctly connected to the AC power terminal of the cabinet.
4. Using a multimeter, check that the power supply reaching the power terminal is 100V/240V.
5. Once the above elements have been verified, power on the PA2 controller cabinet.

#### 9.1.2 Failure to Access Unity Edge User Interface via USB

1. Once the PA2 controller cabinet is powered on, check the local display and ensuring that it shows that the application is running. This may take up to 10 minutes.
2. Connect the USB-C to USB-A cable between the HCC2 (Controller) and the PC/Laptop.
3. Verify that there is a connection link between the HCC2 and the laptop as follows:
  - a. Open the "Command Prompt" in Windows (available in the Windows search menu as "CMD").
  - b. Type the following command: "ping 169.254.1.1" and press Enter.
  - c. If the ping is successful, the following reply will be displayed.

```
Pinging 169.254.1.1 with 32 bytes of data:  
Reply from 169.254.1.1: bytes=32 time<1ms TTL=64  
Reply from 169.254.1.1: bytes=32 time<1ms TTL=64  
Reply from 169.254.1.1: bytes=32 time<1ms TTL=64  
Reply from 169.254.1.1: bytes=32 time<1ms TTL=64
```

4. If instead of "TTL=64," the message observed is "Destination host unreachable" or any type of "Failure", proceed as follows:
  - a. On the laptop, initialize the Device Manager to validate that the USB driver has recognized the connection. The connection is not recognized when an error is observed in the corresponding driver under the "Universal Bus Controllers" section. (Device Manager can be found in the search bar of the Windows menu.)

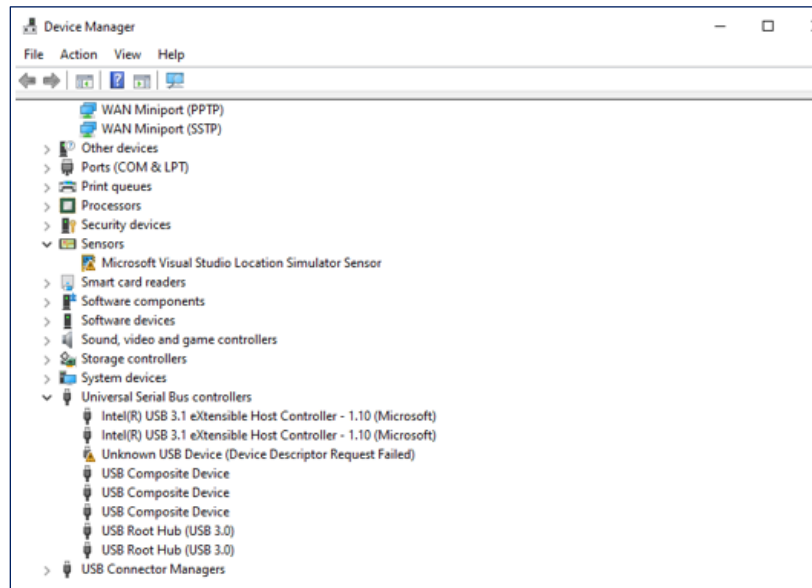

- b. If there is any error, disconnect the USB-A / USB-C cable from the Laptop-Controller and power off the HCC2 controller cabinet.
- c. After a minute or so, power back on the HCC2 controller cabinet and repeat from step 2.
- d. If everything is OK, open the Google Chrome web browser (Incognito Mode), and enter the following address <https://169.254.1.1> to access the Unity Edge interface.
- e. The browser will display the message “Your connection is not private”, click the advanced button and then “Proceed to 169.254.1.1 (unsafe)”.

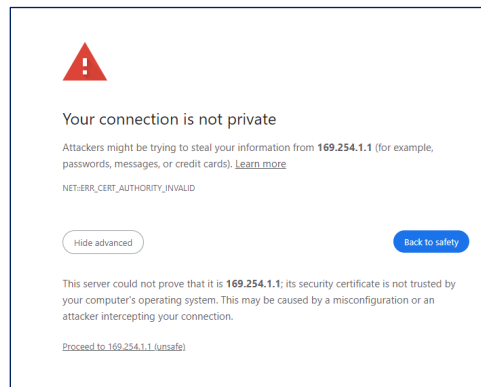

- f. Once this is done, proceed with the log in information.

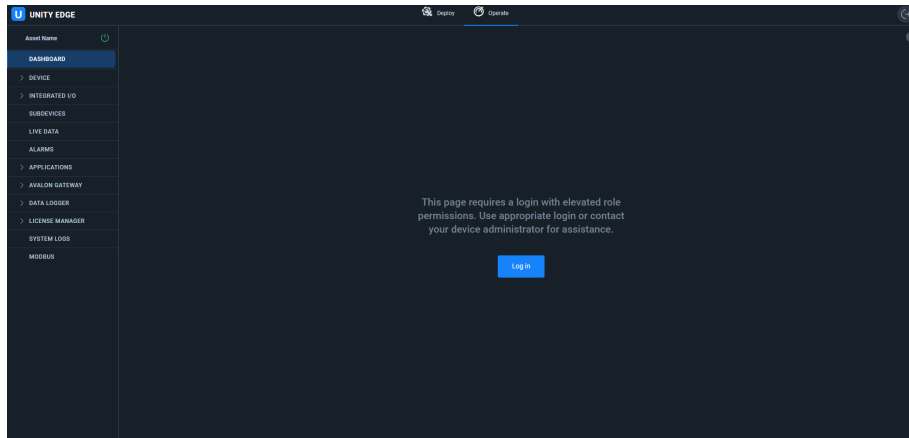

### 9.1.3 PA2 Controller and Avalon Provisioning and Communication Issues

If you are unable to view information in Avalon, you may need to re-provision your device.

First, determine the provisioning status of your device by performing the following steps:

1. Verify the status of the LTE connection. If there is no connection, refer to the [QRATE HCC2 Software User Manual](#) or contact Sensia Technical Support.
2. In the top panel, select the "Operate" tab. Then, in the navigation tree, select Avalon Gateway>CP Avalon Monitoring.

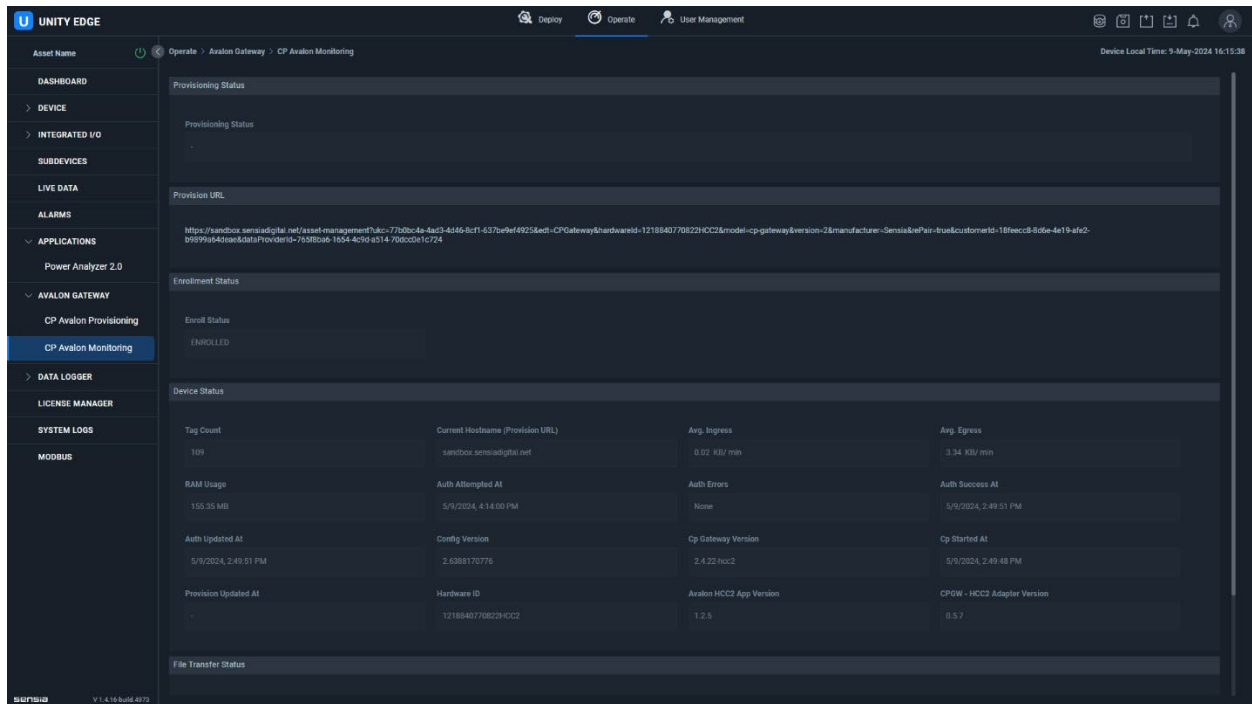

3. On the screen, verify that the Enrollment Status is "ENROLLED".
4. If the above conditions are not met, re-provision your device as described below.

### Reprovisioning the HCC2 Controller

To re-provision the HCC2 for communicating with Avalon,

1. Click Avalon Gateway>Avalon Provisioning in the navigation tree.
2. Enter the URL for the production environment (sps.avalon.sensiadigital.io).
3. Click the blue Provision button.

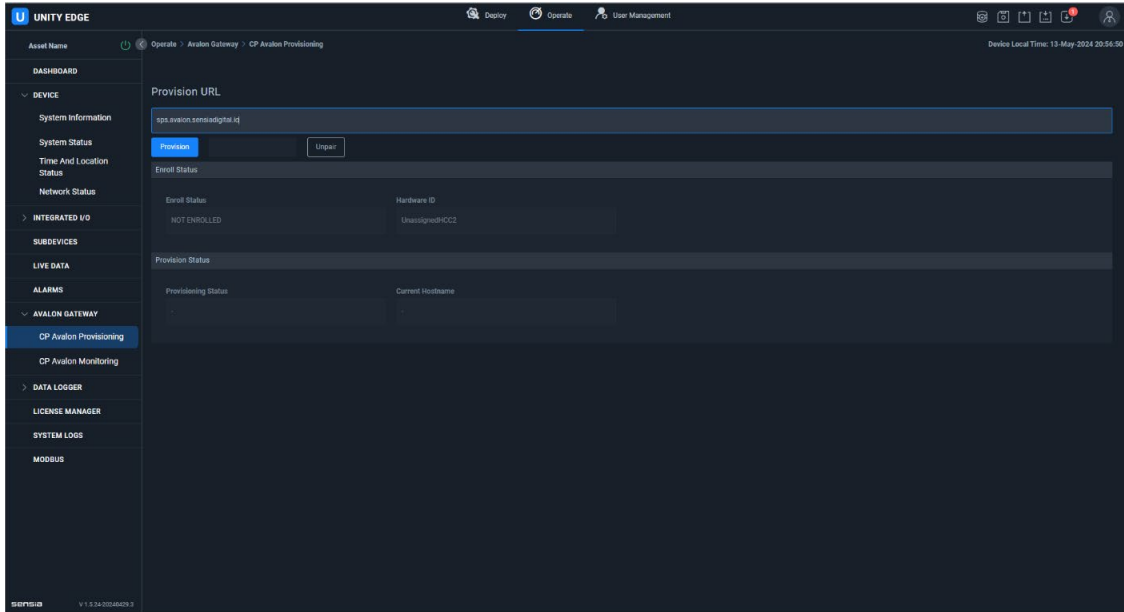

4. A URL confirmation message will appear. Click the X in the right corner to close the message.

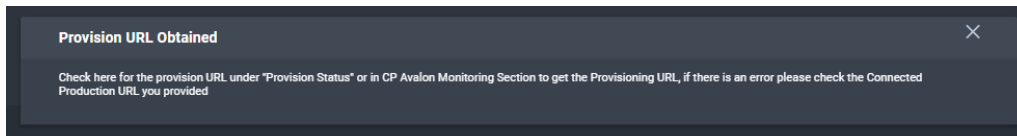

5. After a few seconds, the green provisioning link (Provision Link) will appear on the screen.

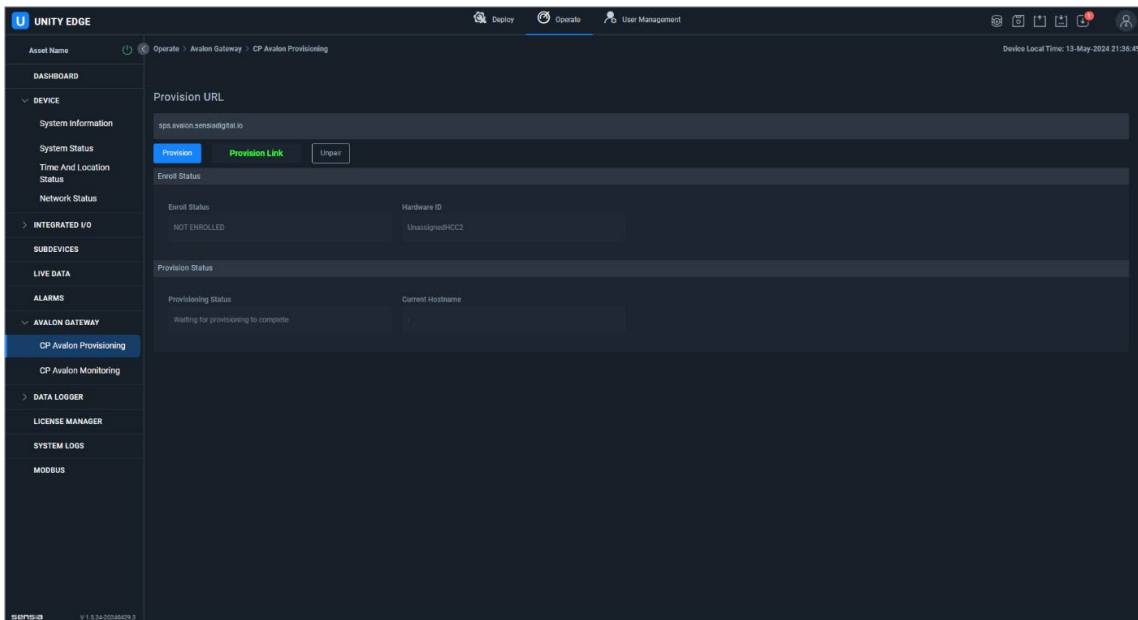

6. Click the green link to open an Avalon login dialog in the internet browser.
7. Enter your previously assigned credentials to log in.

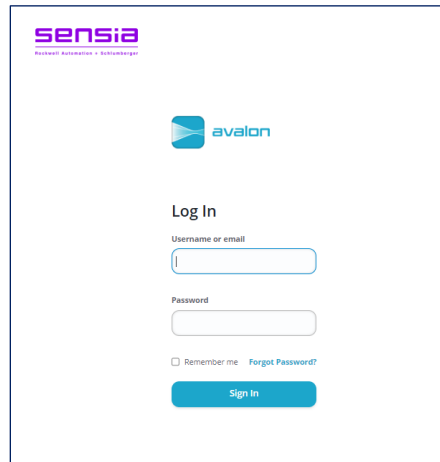

8. In the Avalon interface, a message will appear indicating that the re-provisioning (or “re-pairing”) was successful. Click OK to proceed.

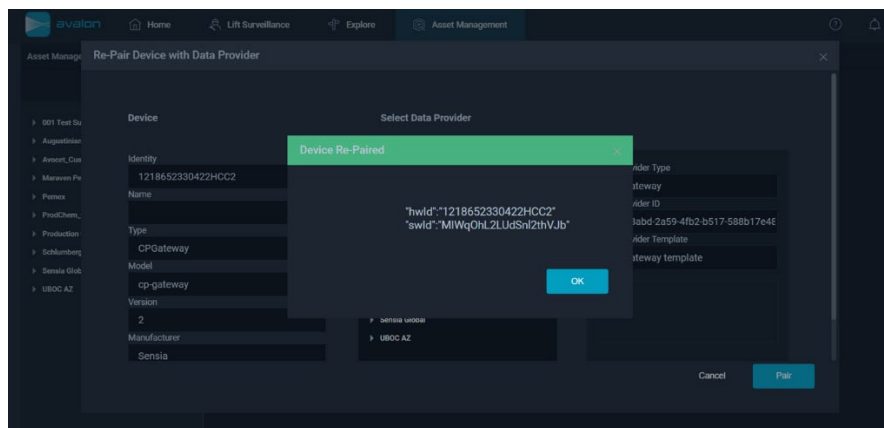

9. Follow the instructions from to verify Avalon connectivity and data streaming ([section 5.5](#)).

#### 9.1.4 Parameter values in HMI or Unity Edge screens appear stagnant or frozen

If you observe stagnant values in your HMI or Unity Edge screen, check the status of your user license by logging into the Unity Edge interface and navigating to the License Manager screen ([Figure 2.5](#)). License status can only be confirmed via Unity Edge software. There is no access from your local HMI.

If the user license is expired, contact Sensia Technical Support for renewal options.

If the user license is not expired, proceed with troubleshooting to determine other causes.

## 9.2 APPLICATIONS TROUBLESHOOTING

This section describes issues that can arise with this type of application, possible causes, and possible solutions.

**Table 9.1—Applications Diagnostics**

Symptom	Underlying Cause
Negative drive voltage frequency/speed	Reversed connection of cable or sensor. Sequence is ACB instead of ABC, i.e., B lags 120 degrees and C lags 240 degrees behind A.
Negative drive voltage frequency/speed	Reversed connection of current sensors. If both voltage and current sensors are negative a reversed cable is the probable cause.
High zero sequence voltage	Indicated unbalanced insulation to Armor. The most probably cause is the beginning insulator break down of a cable or stator winding on one phase.
High current imbalance	Indicates high cable asymmetry. For flat cables a small asymmetry is expected. The most probable cause for high imbalance is insulator break down at two points in the system. Part of the current then bypasses the motor windings and runs from leakage-to-leakage point.
High voltage THD	Common with six pulse drives. Otherwise, a drive quality indicator. Probable cause for high voltage THD is an undersized line filter or step-up transformer that saturates.
High current THD	Current THD typically rises with higher frequency and magnitude. If the boost voltage or the V/Hz ratio is too high this can lead to high magnetization current and therefore saturation effects. Lower magnetization current will lead to less THD and lower core loss, but can lead to higher copper loss with high power factor.
High slip	During ramp up there is a high risk of tripping the drive with over currents. In general, there is a high risk of stalling. When slip exceeds critical slip, torque does not increase but reduces with reducing speed.
Low torque	Indicates a very low flow rate
Low current	Indicates low flow, then current is dominated by the magnetization (flux) current only and not by the torque current.
Current or voltage RMS error relative to expectations or external validation measurements	Wrong scaling factors in the configuration file or bad sensor connections
High PA2 magnitude	Motor winding or shaft vibration (pump, protector, motor). Probable cause is pump wear.
PA2 frequency	If PA2 (vibration) magnitude is rising and its tone is at a subharmonic (0.3-0.45 x fdrive) it indicates pump wear.
Wrong current or voltage phasor	Sensors or cables are not wired up properly or there is high imbalance on the phase impedance

## Section 10: Integrating the HCC2 and INSTRUMENT Motor Controller via Modbus

The PA2 application provides several parameters for monitoring, control, and analytics of the ESP well. These variables are measured and calculated based on internal algorithms and real-time data obtained from the three-phase voltages and currents. Additionally, the system can integrate other critical data from the well, including:

- Downhole gauge data
- Surface data
- General drive parameters for monitoring and control

The PA2 receives and gathers all ESP and well information from an INSTRUMENT motor controller via Modbus protocol over an RS-485 serial connection.

### 10.1 PRELOADED MODBUS PROTOCOL MAPPINGS

A standard Modbus Protocol Definition File (PDEF) defines mappings for HCC2-supported communication protocols and is preloaded into the HCC2 before shipment. It assumes the surface sensors are wired to Analog Input Card A in the following order:

- Channel 1: Tubing
- Channel 2: Casing

The following table shows the Modbus addresses of each INSTRUMENT Motor Controller Analog Input channel.

HCC2 Address (PDEF)	INSTRUMENT Address	Description
2124	302125	Analog Input A Channel 1
2125	302126	Analog Input A Channel 2
2126	302127	Analog Input A Channel 3
2127	302128	Analog Input A Channel 4
30502	330503	Analog Input B Channel 1
30503	330504	Analog Input B Channel 2
30504	330505	Analog Input B Channel 3
30505	330506	Analog Input B Channel 4



#### CAUTION

For systems with a different setup, the PDEF must be updated to reflect the correct wiring of the surface sensors. Contact Sensia Technical Support for assistance.

For proper integration of the HCC2 and the INSTRUMENT motor controller for Modbus communications, follow the instructions provided below.

## 10.2 HCC2/INSTRUCT SERIAL COMMUNICATIONS WIRING

Install a half-duplex serial communication cable between the HCC2 and the INSTRUCT Motor Controller as follows to enable data transfer via the MODBUS RTU protocol over RS-485.

1. Install jumper cables on the INSTRUCT RS-485 main board, connecting TX+ / RX + (Pin 1 – Pin 4) and TX- / RX- (Pin 2 – Pin 3).

Pin Number (Top to bottom)	Pin Name	Function
1	TX+	RS-485 Transmit Positive
2	TX-	RS-485 Transmit Negative
3	RX-	RS-485 Receive Negative
4	RX+	RS-485 Receive Positive
5	GND	Isolated Signal Ground (Connect the cable shield to this pin at the controller end only)



3. Install a 3-wire cable from the RS485 port on the INSTRUCT controller to Port 3 on the HCC2 (as shown below).

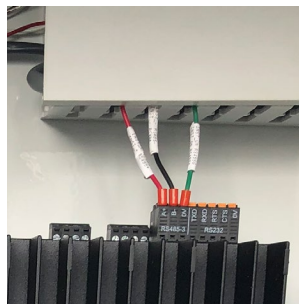
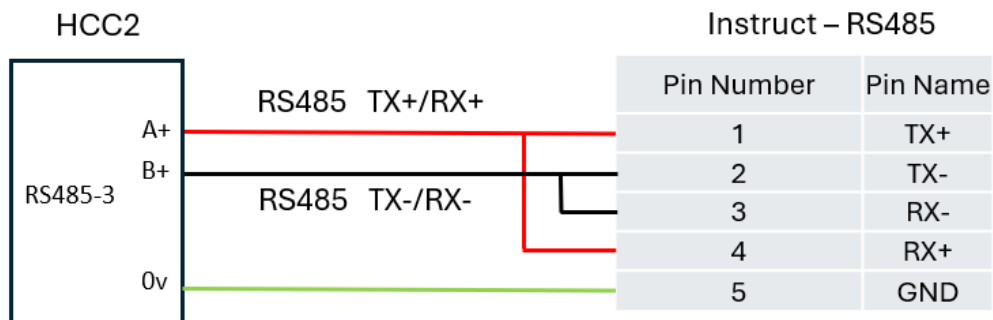

### 10.3 CONFIGURE INSTRUMENT MOTOR MODBUS RTU SERVER SETTINGS

Update the Modbus RTU Server settings on the INSTRUMENT controller using either the INSTRUMENT local HMI keypad or the StarView tool. The settings should match those shown in the following screen:

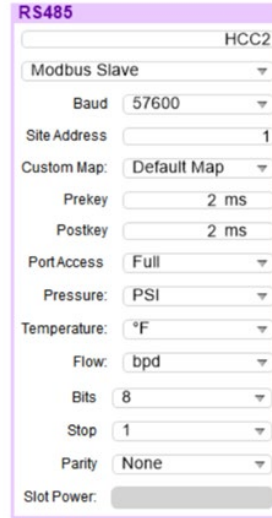

### 10.4 CONFIGURE HCC2 CONTROLLER MODBUS RTU CLIENT SETTINGS

1. Connect the HCC2 to your laptop via a USB-C cable if not already installed. See [Figure 5.1](#).
2. Log in to the Unity Edge interface as described in [section 5.3.1](#).
3. Update serial port settings as required using these steps:
  - a. Click the Deploy tab at the top of the screen.
  - b. Navigate to System>Communication>Serial Ports and verify or change the settings to the following:

Serial Ports		Server TCP Ports		Client TCP Ports			
Port	Baud	Parity	Stop	Terminate	Rx Bus Timeout (ms)	Tx Bus Delay (ms)	Protocol
RS485-1	19200	None	1 bits	<input type="checkbox"/>	100.000	10.000	Disabled
RS485-2	19200	None	1 bits	<input type="checkbox"/>	100.000	10.000	Disabled
RS485-3	57600	None	1 bits	<input checked="" type="checkbox"/>	1000.000	10.000	Modbus Client
RS485-4	19200	None	1 bits	<input type="checkbox"/>	100.000	10.000	Disabled
RS485-5	19200	None	1 bits	<input type="checkbox"/>	100.000	10.000	Disabled
RS232	9600	None	1 bits	<input type="checkbox"/>	100.000	10.000	Disabled

- c. If you updated settings, click the Update Deployment File button in the bottom right corner of the screen.
4. Update Modbus protocol as required using these steps:
  - a. Navigate to Protocols>Modbus.
  - b. Verify that the appropriate PDEF file containing all the pre-configured Modbus data information is attached to the Protocol Def File field.
  - c. If the proper PDEF file is not loaded, attach the proper PDEF file.
  - d. In the Client Tag ID field, enter “instruct”.

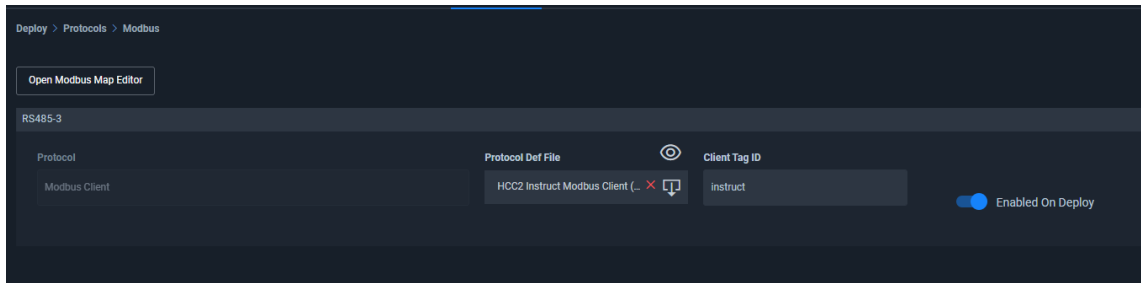

- e. If you updated settings, click the Update Deployment File button.
- 5. Click **DEPLOY** in the navigation tree on the left and click **Start** to initiate the workflow and deploy all the changes to the HCC2.

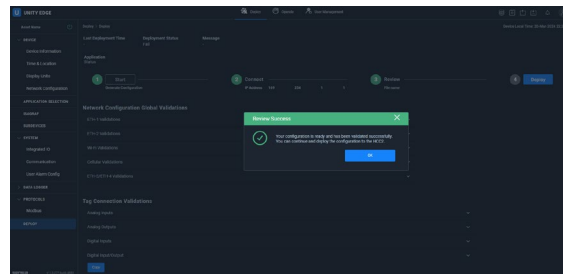

- 6. Click **OK** to close the configuration validation message and click **Deploy**.

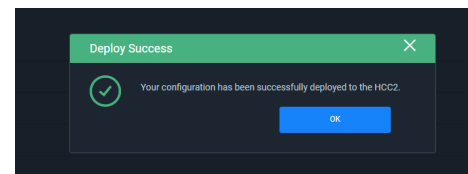
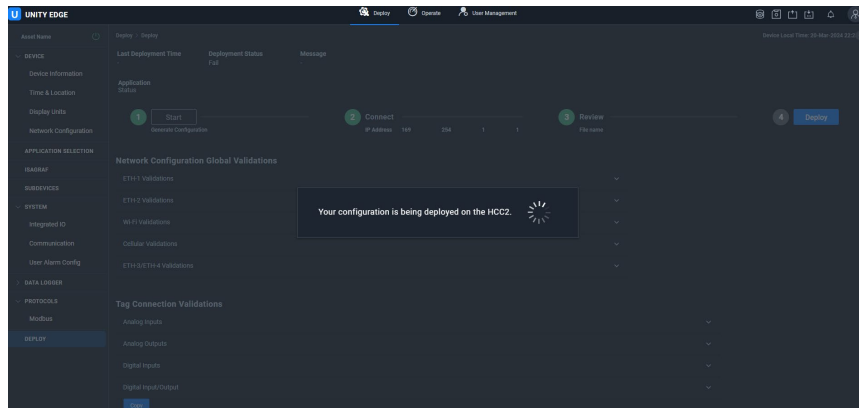

- 7. Click **OK** in the Deploy Success message screen to complete the Modbus integration of the HCC2 and INSTRUCT controllers.

### 10.4.1 Verify the Modbus Integration

To test this integration, proceed as follows:

1. Make sure the INSTRUCT motor controller is powered on.
2. Click the Operate tab at the top of the Unity Edge UI.
3. Navigate to Live Data in the navigation tree and locate the search field at the top of the screen.
4. Enter “instruct” and observe the live data to verify values are updating.

The screenshot shows the Unity Edge interface with the 'Operate' tab selected. The 'Live Data' section is active, and a search for 'instruct' has been performed. The table below displays the results of the search.

Data Quality	Browser Time	Tag Name	Current Value	Unit
	20-Mar-2024 17:58:04	user_modbus_RS485-3_client_instruct_0: Instruct Controller: DIS: Controller Mode Manual Off	false	
	20-Mar-2024 17:58:04	user_modbus_RS485-3_client_instruct_0: Instruct Controller: DIS: Controller Mode Hand	false	
	20-Mar-2024 17:58:04	user_modbus_RS485-3_client_instruct_0: Instruct Controller: DIS: Controller Mode Auto	true	
	20-Mar-2024 17:58:05	user_modbus_RS485-3_client_instruct_0: Instruct Controller: DIS: Drive Running	true	
	20-Mar-2024 17:58:05	user_modbus_RS485-3_client_instruct_0: Instruct Controller: HR-R: Pump Intake Pressure High Trip Setpoint	34473.8	kPa(g)
	20-Mar-2024 17:58:05	user_modbus_RS485-3_client_instruct_0: Instruct Controller: HR-R: Pump Intake Pressure Low Alarm Setpoint	689.5	kPa(g)
	20-Mar-2024 17:58:05	user_modbus_RS485-3_client_instruct_0: Instruct Controller: HR-R: Pump Intake Pressure Low Trip Time	45.00	s
	20-Mar-2024 17:58:05	user_modbus_RS485-3_client_instruct_0: Instruct Controller: HR-R: Pump Intake Pressure Low Trip Action	0.00000	
	20-Mar-2024 17:58:05	user_modbus_RS485-3_client_instruct_0: Instruct Controller: HR-R: Pump Intake Pressure Number of Restarts	3	
	20-Mar-2024 17:58:05	user_modbus_RS485-3_client_instruct_0: Instruct Controller: HR-R: Pump Intake Pressure Low Trip Restart Time	1800.00	s
	20-Mar-2024 17:58:05	user_modbus_RS485-3_client_instruct_0: Instruct Controller: HR-R: Pump Intake Pressure Low Start Bypass Time	0.00	s
	20-Mar-2024 17:58:05	user_modbus_RS485-3_client_instruct_0: Instruct Controller: IR: Drive Input Power	0.000	W
	20-Mar-2024 17:58:05	user_modbus_RS485-3_client_instruct_0: Instruct Controller: IR: Drive Output Power	251240.000	W
	20-Mar-2024 17:58:05	user_modbus_RS485-3_client_instruct_0: Instruct Controller: COIL-R: Drive Gas Lock Protection Enabled	false	
	20-Mar-2024 17:58:05	user_modbus_RS485-3_client_instruct_0: Instruct Controller: HR-R: Pump Discharge Pressure High Alarm Setpoint	34473.8	kPa(g)
	20-Mar-2024 17:58:05	user_modbus_RS485-3_client_instruct_0: Instruct Controller: HR-R: Pump Discharge Pressure High Trip Time	45.00	s
	20-Mar-2024 17:58:05	user_modbus_RS485-3_client_instruct_0: Instruct Controller: IR: Tubing Head Pressure	1854.7	kPa(g)
	20-Mar-2024 17:58:05	user_modbus_RS485-3_client_instruct_0: Instruct Controller: IR: Casing Head Pressure	1516.8	kPa(g)

Alternatively, you can verify the integration by clicking on the Operate tab and navigating to the Modbus menu in the navigation tree. If the integration was successful, the Modbus port statistics and byte counts displayed on the Port screen shown below will update.

The screenshot shows the Unity Edge interface with the 'Operate' tab selected. The 'Modbus' menu is active, and the 'Port' screen is displayed. The table below shows the Modbus port statistics.

Port	Status	Protocol	Bytes/sec	Byte Count Tx/Rx	Bus Timeout Count	Overrun Errors	Frame Errors	Parity Errors	User Action
RS485-3	Enabled	Modbus Client	123.75	21652894 / 23835552	0	0	0	0	Reset stats

## Appendix A: HCC2/INSTRUCT Modbus Reference Guide

This guide contains the Modbus map required to integrate the INSTRUCT motor controller and the HCC2 controller.

For information about HCC2 Modbus communications specifications and configuration, refer to the [QRATE HCC2 Software User Manual](#).

Function Type	Tag Description	HCC2 Modbus Address	HCC2 Tag Data Type	INSTRUCT Modbus Address	INSTRUCT Register Data Type	INSTRUCT Register Engineering Units	INSTRUCT Register Scale Factor
Read Discrete	INSTRUCT Locked Out	412	Bool	100413	BOOL	-	-
Read Discrete	Controller Mode Manual Off	413	Bool	100414	BOOL	-	-
Read Discrete	Controller Mode Hand	414	Bool	100415	BOOL	-	-
Read Discrete	Controller Mode Auto	415	Bool	100416	BOOL	-	-
Read Discrete	Drive Running	431	Bool	100432	BOOL	-	-
Read Input	INSTRUCT Serial Number	3	Int64	300004	UINT32	NONE.none	1
Read Input	Drive Latched Alarms 0	2040	Int64	302041	UINT16	NONE.none	1
Read Input	Drive Latched Alarms 1	2041	Int64	302042	UINT16	NONE.none	1
Read Input	Drive Latched Alarms 2	2042	Int64	302043	UINT16	NONE.none	1
Read Input	Drive Latched Alarms 3	2043	Int64	302044	UINT16	NONE.none	1
Read Input	Drive Alarms 0	2048	Int64	302049	UINT16	NONE.none	1
Read Input	Drive Alarms 1	2049	Int64	302050	UINT16	NONE.none	1
Read Input	Drive Alarms 2	2050	Int64	302051	UINT16	NONE.none	1
Read Input	Drive Alarms 3	2051	Int64	302052	UINT16	NONE.none	1
Read Input	Drive Number of Starts	2064	Double	302065	UINT16	NONE.none	1
Read Input	Drive Run Hours	2076	Double	302077	UINT32	TIME.s	1
Read Input	Drive Off Hours	2078	Double	302079	UINT32	TIME.s	1
Read Input	Drive Total Run Time	2080	Double	302081	UINT32	TIME.s	1
Read Input	Drive Shutdown Cause	2088	Int64	302089	UINT16	NONE.none	1
Read Input	INSTRUCT Internal Temperature	2102	Double	302103	UINT16	TEMP.degF	1
Read Input	Drive Supply Voltage	2103	Double	302104	UINT16	VOLT.V	1
Read Input	Tubing Head Pressure (see also <a href="#">section 10.1</a> )	2124	Double	302125	UINT16	SPG.psig	1
Read Input	Casing Head Pressure (see also <a href="#">section 10.1</a> )	2125	Double	302126	UINT16	SPG.psig	1
Read Input	Tubing Head Temperature	2126	Double	302127	UINT16	TEMP.degF	1

Function Type	Tag Description	HCC2 Modbus Address	HCC2 Tag Data Type	INSTRUCT Modbus Address	INSTRUCT Register Data Type	INSTRUCT Register Engineering Units	INSTRUCT Register Scale Factor
Read Input	Flow Line Pressure	2127	Double	302128	UINT16	SPG.psig	1
Read Input	Pump Intake Pressure	2136	Double	302137	UINT16	SPG.psig	10
Read Input	Pump Discharge Pressure	2137	Double	302138	UINT16	SPG.psig	10
Read Input	Pump Intake Temperature	2139	Double	302140	UINT16	TEMP.degF	10
Read Input	Motor Temperature	2140	Double	302141	UINT16	TEMP.degF	10
Read Input	Vibration	2141	Double	302142	UINT16	ACC.m/s2	1000
Read Input	Downhole Gauge Active Current Leakage	2142	Double	302143	UINT16	CUR.mA	1000
Read Input	Phoenix Interface Card Status	2143	Int64	302144	UINT16	NONE.none	1
Read Input	Downhole Gauge Current Zero	2144	Double	302145	UINT16	CUR.mA	1000
Read Input	Downhole Gauge Current Full	2145	Double	302146	UINT16	CUR.mA	1000
Read Input	Downhole Gauge Passive Current Leakage	2147	Double	302148	UINT16	CUR.mA	1000
Read Input	Pump Discharge Temperature	2148	Double	302149	UINT16	TEMP.degF	10
Read Input	Tool Type	2160	Int64	302161	UINT16	NONE.none	1
Read Input	Pump Differential Pressure	2161	Double	302162	UINT16	SPG.psig	1
Read Input	PIC Firmware Version	2164	Double	302165	UINT16	NONE.none	1000
Read Input	Drive Output Frequency	2165	Double	302166	UINT16	FREQ.Hz	100
Read Input	Drive Input Voltage	2169	Double	302170	UINT16	VOLT.V	10
Read Input	Drive Output Voltage Average	2170	Double	302171	UINT16	VOLT.V	10
Read Input	Drive Loading	2173	Double	302174	UINT16	PRCNT.%	100
Read Input	Drive Output Current Average	2174	Double	302175	UINT16	CUR.A	10
Read Input	Drive Motor Current Average	2175	Double	302176	UINT16	CUR.A	10
Read Input	Drive Torque Current	2176	Double	302177	UINT16	CUR.A	100
Read Input	Drive Input Power	2178	Double	302179	UINT16	POW.kW	100
Read Input	Drive Output Power	2179	Double	302180	UINT16	POW.kW	100
Read Coil	Drive Remote Stop	0	Bool	1	BOOL	-	-
Read Coil	Drive Remote Start	2	Bool	3	BOOL	-	-
Read Coil	Drive Clear Latched Alarms	3	Bool	4	BOOL	-	-
Read Coil	Drive Clear Lockout	4	Bool	5	BOOL	-	-

Function Type	Tag Description	HCC2 Modbus Address	HCC2 Tag Data Type	INSTRUCT Modbus Address	INSTRUCT Register Data Type	INSTRUCT Register Engineering Units	INSTRUCT Register Scale Factor
Read Coil	Drive Set Passive Current Leakage	7	Bool	8	BOOL	-	-
Read Coil	Drive Reset Phoenix Interface Card	8	Bool	9	BOOL	-	-
Read Coil	Drive Catch Spinning Motor	39	Bool	40	BOOL	-	-
Read Coil	Drive Rotation Direction	43	Bool	44	BOOL	-	-
Read Coil	Drive Auto Restart Enabled	52	Bool	53	BOOL	-	-
Read Coil	Drive Gas Lock Protection Enabled	5000	Bool	5001	BOOL	-	-
Write Coil	Drive Request Remote Stop	0	Bool	1	BOOL	-	-
Write Coil	Drive Request Remote Start	2	Bool	3	BOOL	-	-
Write Coil	Drive Request Clear Latched Alarms	3	Bool	4	BOOL	-	-
Write Coil	Drive Request Clear Lockout	4	Bool	5	BOOL	-	-
Write Coil	Drive Request Set Passive Current Leakage	7	Bool	8	BOOL	-	-
Write Coil	Drive Request Reset Phoenix Interface Card	8	Bool	9	BOOL	-	-
Write Coil	Drive Request Catch Spinning Motor	39	Bool	40	BOOL	-	-
Write Coil	Drive Request Rotation Direction	43	Bool	44	BOOL	-	-
Write Coil	Drive Request Auto Restart Enable	52	Bool	53	BOOL	-	-
Write Coil	Drive Request Gas Lock Protection Enable	5000	Bool	5001	BOOL	-	-
Read Holding	Supply Voltage High Alarm Setpoint	187	Double	400188	UINT16	VOLT.V	1
Read Holding	Supply Voltage High Trip Time	188	Double	400189	UINT16	TIME.s	10
Read Holding	Supply Voltage High Trip Action	189	Int64	400190	UINT16	FACT.none	1
Read Holding	Supply Voltage High Trip Restart Time	191	Double	400192	UINT16	TIME.mins	1
Read Holding	Supply Voltage Low Alarm Setpoint	193	Double	400194	UINT16	VOLT.V	1
Read Holding	Supply Voltage Low Trip Time	194	Double	400195	UINT16	TIME.s	10
Read Holding	Supply Voltage Low Trip Action	195	Int64	400196	UINT16	FACT.none	1
Read Holding	Supply Voltage Low Trip Restart Time	197	Double	400198	UINT16	TIME.mins	1
Read Holding	Underload Track Target	262	Double	400263	UINT16	PRCNT.%	1

Function Type	Tag Description	HCC2 Modbus Address	HCC2 Tag Data Type	INSTRUCT Modbus Address	INSTRUCT Register Data Type	INSTRUCT Register Engineering Units	INSTRUCT Register Scale Factor
Read Holding	Underload Tracking	263	Int64	400264	UINT16	NONE.none	1
Read Holding	Drive Motor Nominal RPM	375	Double	400376	UINT16	NONE.none	1
Read Holding	Pump Intake Pressure High Trip Setpoint	502	Double	400503	UINT16	SPG.psig	10
Read Holding	Pump Intake Pressure Low Alarm Setpoint	508	Double	400509	UINT16	SPG.psig	10
Read Holding	Pump Intake Pressure Low Trip Time	509	Double	400510	UINT16	TIME.s	10
Read Holding	Pump Intake Pressure Low Trip Action	510	Int64	400511	UINT16	FACT.none	1
Read Holding	Pump Intake Pressure Number of Restarts	511	Double	400512	UINT16	NONE.none	1
Read Holding	Pump Intake Pressure Low Trip Restart Time	512	Double	400513	UINT16	TIME.mins	1
Read Holding	Pump Intake Pressure Low Start Bypass Time	513	Double	400514	UINT16	TIME.s	10
Read Holding	Pump Discharge Pressure High Alarm Setpoint	514	Double	400515	UINT16	SPG.psig	10
Read Holding	Pump Discharge Pressure High Trip Time	515	Double	400516	UINT16	TIME.s	10
Read Holding	Pump Discharge Pressure High Trip Action	516	Int64	400517	UINT16	FACT.none	1
Read Holding	Pump Discharge Pressure High Restart Time	518	Double	400519	UINT16	TIME.mins	1
Read Holding	Pump Discharge Pressure High Start Bypass Time	519	Double	400520	UINT16	TIME.s	10
Read Holding	Pump Discharge Pressure Low Alarm Setpoint	520	Double	400521	UINT16	SPG.psig	10
Read Holding	Pump Intake Temperature High Alarm Setpoint	538	Double	400539	UINT16	TEMP.degF	10
Read Holding	Bottomhole Temperature Trip Time	539	Double	400540	UINT16	TIME.s	10
Read Holding	Bottomhole Temperature Trip Action	540	Int64	400541	UINT16	FACT.none	1
Read Holding	Pump Intake Temperature Number of Restarts	541	Double	400542	UINT16	NONE.none	1
Read Holding	Bottomhole Temperature Trip Restart Time	542	Double	400543	UINT16	TIME.mins	1
Read Holding	Bottomhole Temperature Start Bypass Time	543	Double	400544	UINT16	TIME.s	10
Read Holding	Motor Temperature High Alarm Setpoint	544	Double	400545	UINT16	TEMP.degF	10

Function Type	Tag Description	HCC2 Modbus Address	HCC2 Tag Data Type	INSTRUCT Modbus Address	INSTRUCT Register Data Type	INSTRUCT Register Engineering Units	INSTRUCT Register Scale Factor
Read Holding	Motor Winding Temperature Trip Time	545	Double	400546	UINT16	TIME.s	10
Read Holding	Motor Winding Temperature Trip Action	546	Int64	400547	UINT16	FACT.none	1
Read Holding	Motor Temperature Number of Restarts	547	Int64	400548	UINT16	NONE.none	1
Read Holding	Motor Winding Temperature Trip Restart Time	548	Double	400549	UINT16	TIME.mins	1
Read Holding	Motor Winding Temperature Start Bypass Time	549	Double	400550	UINT16	TIME.s	10
Read Holding	Vibration High Alarm Setpoint	550	Double	400551	UINT16	ACC.m/s2	1000
Read Holding	Vibration High Trip Time	551	Double	400552	UINT16	TIME.s	10
Read Holding	Vibration High Trip Action	552	Int64	400553	UINT16	FACT.none	1
Read Holding	Vibration High Trip Restart Time	554	Double	400555	UINT16	TIME.mins	1
Read Holding	Active Current Leakage High Alarm Setpoint	556	Double	400557	UINT16	CUR.mA	1000
Read Holding	Active Current Leakage High Trip Action	558	Int64	400559	UINT16	FACT.none	1
Read Holding	Passive Current Leakage High Alarm Setpoint	562	Double	400563	UINT16	CUR.mA	1000
Read Holding	Passive Current Leakage High Trip Action	564	Int64	400565	UINT16	FACT.none	1
Read Holding	Pump Delta P High Trip Setpoint	652	Double	400653	UINT16	SPG.psig	1
Read Holding	Pump Delta P Low Trip Setpoint	658	Double	400659	UINT16	SPG.psig	1
Read Holding	Transformer Ratio	716	Double	400717	UINT16	NONE.none	100
Read Holding	Overload Alarm Setpoint	717	Double	400718	UINT16	CUR.A	10
Read Holding	Overload Trip Time	718	Double	400719	UINT16	TIME.s	10
Read Holding	Overload Trip Action	719	Int64	400720	UINT16	FACT.none	1
Read Holding	Overload Number of Restarts	720	Double	400721	UINT16	NONE.none	1
Read Holding	Overload Restart Time	721	Double	400722	UINT16	TIME.mins	1
Read Holding	Overload Start Bypass	722	Double	400723	UINT16	TIME.s	10
Read Holding	Underload Alarm Setpoint	751	Double	400752	UINT16	CUR.A	10

Function Type	Tag Description	HCC2 Modbus Address	HCC2 Tag Data Type	INSTRUCT Modbus Address	INSTRUCT Register Data Type	INSTRUCT Register Engineering Units	INSTRUCT Register Scale Factor
Read Holding	Underload Trip Time	752	Double	400753	UINT16	TIME.s	10
Read Holding	Drive Underload Trip Action	753	Int64	400754	UINT16	FACT.none	1
Read Holding	Underload Number of Restarts	754	Double	400755	UINT16	NONE.none	1
Read Holding	Underload Restart Time	755	Double	400756	UINT16	TIME.mins	1
Read Holding	Underload Start Bypass	756	Double	400757	UINT16	TIME.s	10
Read Holding	Feedback Setpoint	759	Double	400760	UINT16	NONE.none	10
Read Holding	Feedback Step Size	760	Double	400761	UINT16	FREQ.Hz	100
Read Holding	Feedback Step Interval	761	Double	400762	UINT16	TIME.s	1
Read Holding	Drive Extended Ramp Enable	762	Int64	400763	UINT16	FACT.none	1
Read Holding	Extended Ramp Rate Step Size	763	Double	400764	UINT16	FREQ.Hz	100
Read Holding	Extended Ramp Rate Step Interval	764	Double	400765	UINT16	TIME.s	1
Read Holding	Feedback Polarity Setpoint	765	Int64	400766	UINT16	NONE.none	1
Read Holding	Drive Ramp Frequency	854	Double	400855	UINT16	FREQ.Hz	100
Read Holding	Drive Frequency Target	855	Double	400856	UINT16	FREQ.Hz	100
Read Holding	Drive Frequency Minimum	856	Double	400857	UINT16	FREQ.Hz	100
Read Holding	Drive Frequency Maximum	857	Double	400858	UINT16	FREQ.Hz	100
Read Holding	Drive Deceleration Ramp Time	858	Double	400859	UINT16	TIME.s	10
Read Holding	Drive Acceleration Ramp Time	859	Double	400860	UINT16	TIME.s	10
Read Holding	Drive Base Frequency	863	Double	400864	UINT16	FREQ.Hz	100
Read Holding	Drive Base Voltage	864	Double	400865	UINT16	VOLT.V	1
Read Holding	Drive Start Frequency	865	Double	400866	UINT16	FREQ.Hz	100
Read Holding	Drive Volts Hz Pattern	867	Int64	400868	UINT16	NONE.none	1
Read Holding	Drive Startup Voltage Boost	869	Double	400870	UINT16	PRCNT.%	10
Read Holding	Drive Thermal Stall Setpoint	871	Double	400872	UINT16	PRCNT.%	1
Read Holding	Jump Frequency 1	872	Double	400873	UINT16	FREQ.Hz	100

Function Type	Tag Description	HCC2 Modbus Address	HCC2 Tag Data Type	INSTRUCT Modbus Address	INSTRUCT Register Data Type	INSTRUCT Register Engineering Units	INSTRUCT Register Scale Factor
Read Holding	Jump Width 1	873	Double	400874	UINT16	FREQ.Hz	100
Read Holding	Drive Speed Source	920	Int64	400921	UINT16	FACT.none	1
Read Holding	Feedback Deadband	928	Double	400929	UINT16	PRCNT.%	10
Write Holding	Drive Request Supply Voltage High Alarm Setpoint	187	Double	400188	UINT16	VOLT.V	1
Write Holding	Drive Request Supply Voltage High Trip Time	188	Double	400189	UINT16	TIME.s	10
Write Holding	Drive Request Supply Voltage High Trip Action	189	Int64	400190	UINT16	FACT.none	1
Write Holding	Drive Request Supply Voltage High Trip Restart Time	191	Double	400192	UINT16	TIME.mins	1
Write Holding	Drive Request Supply Voltage Low Alarm Setpoint	193	Double	400194	UINT16	VOLT.V	1
Write Holding	Drive Request Supply Voltage Low Trip Time	194	Double	400195	UINT16	TIME.s	10
Write Holding	Drive Request Supply Voltage Low Trip Action	195	Int64	400196	UINT16	FACT.none	1
Write Holding	Drive Request Supply Voltage Low Trip Restart Time	197	Double	400198	UINT16	TIME.mins	1
Write Holding	Drive Request Underload Track Target	262	Double	400263	UINT16	PRCNT.%	1
Write Holding	Drive Request Underload Tracking	263	Int64	400264	UINT16	NONE.none	1
Write Holding	Drive Request Motor Nominal RPM	375	Double	400376	UINT16	NONE.none	1
Write Holding	ESP Request Pump Intake Pressure High Trip Setpoint	502	Double	400503	UINT16	SPG.psig	10
Write Holding	ESP Request Pump Intake Pressure Low Alarm Setpoint	508	Double	400509	UINT16	NONE.none	10
Write Holding	ESP Request Pump Intake Pressure Low Trip Time	509	Double	400510	UINT16	TIME.s	10
Write Holding	ESP Request Pump Intake Pressure Low Trip Action	510	Int64	400511	UINT16	FACT.none	1
Write Holding	ESP Request Pump Intake Pressure Number of Restarts	511	Double	400512	UINT16	NONE.none	1
Write Holding	ESP Request Pump Intake Pressure Low Trip Restart Time	512	Double	400513	UINT16	TIME.mins	1

Function Type	Tag Description	HCC2 Modbus Address	HCC2 Tag Data Type	INSTRUCT Modbus Address	INSTRUCT Register Data Type	INSTRUCT Register Engineering Units	INSTRUCT Register Scale Factor
Write Holding	ESP Request Pump Intake Pressure Low Start Bypass Time	513	Double	400514	UINT16	TIME.s	10
Write Holding	ESP Request Pump Discharge Pressure High Alarm Setpoint	514	Double	400515	UINT16	SPG.psig	10
Write Holding	ESP Request Pump Discharge Pressure High Trip Time	515	Double	400516	UINT16	TIME.s	10
Write Holding	ESP Request Pump Discharge Pressure High Trip Action	516	Int64	400517	UINT16	FACT.none	1
Write Holding	ESP Request Pump Discharge Pressure High Restart Time	518	Double	400519	UINT16	TIME.mins	1
Write Holding	ESP Request Pump Discharge Pressure High Start Bypass Time	519	Double	400520	UINT16	TIME.s	10
Write Holding	ESP Request Pump Discharge Pressure Low Alarm Setpoint	520	Double	400521	UINT16	SPG.psig	10
Write Holding	ESP Request Pump Intake Temperature High Alarm Setpoint	538	Double	400539	UINT16	TEMP.degF	10
Write Holding	ESP Request Bottomhole Temperature Trip Time	539	Double	400540	UINT16	TIME.s	10
Write Holding	ESP Request Bottomhole Temperature Trip Action	540	Int64	400541	UINT16	FACT.none	1
Write Holding	ESP Request Pump Intake Temperature Number of Restarts	541	Double	400542	UINT16	NONE.none	1
Write Holding	ESP Request Bottomhole Temperature Trip Restart Time	542	Double	400543	UINT16	TIME.mins	1
Write Holding	ESP Request Bottomhole Temperature Start Bypass Time	543	Double	400544	UINT16	TIME.s	10
Write Holding	ESP Request Motor Temperature High Alarm Setpoint	544	Double	400545	UINT16	TEMP.degF	10
Write Holding	ESP Request Motor Winding Temperature Trip Time	545	Double	400546	UINT16	TIME.s	10
Write Holding	ESP Request Motor Winding Temperature Trip Action	546	Int64	400547	UINT16	FACT.none	1
Write Holding	ESP Request Motor Temperature Number of Restarts	547	Int64	400548	UINT16	NONE.none	1

Function Type	Tag Description	HCC2 Modbus Address	HCC2 Tag Data Type	INSTRUCT Modbus Address	INSTRUCT Register Data Type	INSTRUCT Register Engineering Units	INSTRUCT Register Scale Factor
Write Holding	ESP Request Motor Winding Temperature Trip Restart Time	548	Double	400549	UINT16	TIME.mins	1
Write Holding	ESP Request Motor Winding Temperature Start Bypass Time	549	Double	400550	UINT16	TIME.s	10
Write Holding	ESP Request Vibration High Alarm Setpoint	550	Double	400551	UINT16	ACC.m/s2	1000
Write Holding	ESP Request Vibration High Trip Time	551	Double	400552	UINT16	TIME.s	10
Write Holding	ESP Request Vibration High Trip Action	552	Int64	400553	UINT16	FACT.none	1
Write Holding	ESP Request Vibration High Trip Restart Time	554	Double	400555	UINT16	TIME.mins	1
Write Holding	ESP Request Active Current Leakage High Alarm Setpoint	556	Double	400557	UINT16	CUR.mA	1000
Write Holding	ESP Request Active Current Leakage High Trip Action	558	Int64	400559	UINT16	FACT.none	1
Write Holding	ESP Request Passive Current Leakage High Alarm Setpoint	562	Double	400563	UINT16	CUR.mA	1000
Write Holding	ESP Request Passive Current Leakage High Trip Action	564	Int64	400565	UINT16	FACT.none	1
Write Holding	ESP Request Pump Delta P High Trip Setpoint	652	Double	400653	UINT16	SPG.psig	1
Write Holding	ESP Request Pump Delta P Low Trip Setpoint	658	Double	400659	UINT16	SPG.psig	1
Write Holding	Drive Request Transformer Ratio	716	Double	400717	UINT16	NONE.none	100
Write Holding	Drive Request Overload Alarm Setpoint	717	Double	400718	UINT16	CUR.A	10
Write Holding	Drive Request Overload Trip Time	718	Double	400719	UINT16	TIME.s	10
Write Holding	Drive Request Overload Trip Action	719	Int64	400720	UINT16	FACT.none	1
Write Holding	Drive Request Overload Number of Restarts	720	Double	400721	UINT16	NONE.none	1
Write Holding	Drive Request Overload Restart Time	721	Double	400722	UINT16	TIME.mins	1
Write Holding	Drive Request Overload Start Bypass	722	Double	400723	UINT16	TIME.s	10
Write Holding	Drive Request Underload Alarm Setpoint	751	Double	400752	UINT16	CUR.A	10
Write Holding	Drive Request Underload Trip Time	752	Double	400753	UINT16	TIME.s	10

Function Type	Tag Description	HCC2 Modbus Address	HCC2 Tag Data Type	INSTRUCT Modbus Address	INSTRUCT Register Data Type	INSTRUCT Register Engineering Units	INSTRUCT Register Scale Factor
Write Holding	Drive Request Underload Trip Action	753	Int64	400754	UINT16	FACT.none	1
Write Holding	Drive Request Underload Number of Restarts	754	Double	400755	UINT16	NONE.none	1
Write Holding	Drive Request Underload Restart Time	755	Double	400756	UINT16	TIME.mins	1
Write Holding	Drive Request Underload Start Bypass	756	Double	400757	UINT16	TIME.s	10
Write Holding	Drive Request Feedback Setpoint	759	Double	400760	UINT16	NONE.none	10
Write Holding	Drive Request Feedback Step Size	760	Double	400761	UINT16	FREQ.Hz	100
Write Holding	Drive Request Feedback Step Interval	761	Double	400762	UINT16	TIME.s	1
Write Holding	Drive Request Extended Ramp Enable	762	Int64	400763	UINT16	FACT.none	1
Write Holding	Drive Request Extended Ramp Rate Step Size	763	Double	400764	UINT16	FREQ.Hz	100
Write Holding	Drive Request Extended Ramp Rate Step Interval	764	Double	400765	UINT16	TIME.s	1
Write Holding	Drive Request Feedback Polarity Setpoint	765	Int64	400766	UINT16	NONE.none	1
Write Holding	Drive Request Ramp Frequency	854	Double	400855	UINT16	FREQ.Hz	100
Write Holding	Drive Request Target Frequency	855	Double	400856	UINT16	FREQ.Hz	100
Write Holding	Drive Request Frequency Minimum	856	Double	400857	UINT16	FREQ.Hz	100
Write Holding	Drive Request Frequency Maximum	857	Double	400858	UINT16	FREQ.Hz	100
Write Holding	Drive Request Deceleration Ramp Time	858	Double	400859	UINT16	TIME.s	10
Write Holding	Drive Request Acceleration Ramp Time	859	Double	400860	UINT16	TIME.s	10
Write Holding	Drive Request Base Frequency	863	Double	400864	UINT16	FREQ.Hz	100
Write Holding	Drive Request Base Voltage	864	Double	400865	UINT16	VOLT.V	1
Write Holding	Drive Request Start Frequency	865	Double	400866	UINT16	FREQ.Hz	100
Write Holding	Drive Request Volts Hz Pattern	867	Int64	400868	UINT16	NONE.none	1
Write Holding	Drive Request Startup Voltage Boost	869	Double	400870	UINT16	PRCNT.%	10
Write Holding	Drive Request Thermal Stall Setpoint	871	Double	400872	UINT16	PRCNT.%	1
Write Holding	Drive Request Jump Frequency 1	872	Double	400873	UINT16	FREQ.Hz	100

Function Type	Tag Description	HCC2 Modbus Address	HCC2 Tag Data Type	INSTRUCT Modbus Address	INSTRUCT Register Data Type	INSTRUCT Register Engineering Units	INSTRUCT Register Scale Factor
Write Holding	Drive Request Jump Width 1	873	Double	400874	UINT16	FREQ.Hz	100
Write Holding	Drive Request Speed Source	920	Int64	400921	UINT16	FACT.none	1
Write Holding	Drive Request Feedback Deadband	928	Double	400929	UINT16	PRCNT.%	10

*This page is intentionally blank.*

## Appendix B: HCC2/PA2 Modbus Reference Guide

This guide contains the Modbus tags for PA2 parameters that are required to integrate the PA2 application (as a Modbus Server) with other systems.

For information about HCC2 Modbus communications specifications and configuration, refer to the [QRATE HCC2 Software User Manual](#).

Group	PA2 Application Tags	Function Type	Modbus Register	Data Type
PA2 Motor Current	Raw Current RMS A	Input Register	6100	Float32
	Raw Current RMS B	Input Register	6102	Float32
	Raw Current RMS C	Input Register	6104	Float32
	Motor Current RMS A	Input Register	6106	Float32
	Motor Current RMS B	Input Register	6108	Float32
	Motor Current RMS C	Input Register	6110	Float32
	Motor Current Pk-Pk A	Input Register	6112	Float32
	Motor Current Pk-Pk B	Input Register	6114	Float32
	Motor Current Pk-Pk C	Input Register	6116	Float32
	Motor Current Offset A	Input Register	6118	Float32
	Motor Current Offset B	Input Register	6120	Float32
	Motor Current Offset C	Input Register	6122	Float32
	Motor Current Calibrated RMS Zero	Input Register	6124	Float32
	Motor Current Positive Sequence	Input Register	6126	Float32
	Motor Current Negative Sequence	Input Register	6128	Float32
	Motor Current Negative Sequence Percent	Input Register	6130	Float32
	Motor Current Zero Sequence	Input Register	6132	Float32
	Motor Current Zero Sequence Percent	Input Register	6134	Float32
PA2 Motor Voltage	Motor Voltage RMS AE	Input Register	6136	Float32
	Motor Voltage RMS BE	Input Register	6138	Float32
	Motor Voltage RMS CE	Input Register	6140	Float32
	Motor Voltage RMS AB	Input Register	6142	Float32
	Motor Voltage RMS BC	Input Register	6144	Float32
	Motor Voltage RMS CA	Input Register	6146	Float32
	Motor Voltage Pk-Pk AE	Input Register	6148	Float32
	Motor Voltage Pk-Pk BE	Input Register	6150	Float32
	Motor Voltage Pk-Pk CE	Input Register	6152	Float32
	Motor Voltage Pk-Pk AB	Input Register	6154	Float32
	Motor Voltage Pk-Pk BC	Input Register	6156	Float32

Group	PA2 Application Tags	Function Type	Modbus Register	Data Type
	Motor Voltage Pk-Pk CA	Input Register	6158	Float32
	Motor Voltage RMS AN	Input Register	6160	Float32
	Motor Voltage RMS BN	Input Register	6162	Float32
	Motor Voltage RMS CN	Input Register	6164	Float32
	Motor Voltage Pk-Pk AN	Input Register	6166	Float32
	Motor Voltage Pk-Pk BN	Input Register	6168	Float32
	Motor Voltage Pk-Pk CN	Input Register	6170	Float32
	Motor Voltage Offset AE	Input Register	6172	Float32
	Motor Voltage Offset BE	Input Register	6174	Float32
	Motor Voltage Offset CE	Input Register	6176	Float32
	Motor Voltage Offset AB	Input Register	6178	Float32
	Motor Voltage Offset BC	Input Register	6180	Float32
	Motor Voltage Offset CA	Input Register	6182	Float32
	Motor Voltage Positive Sequence	Input Register	6184	Float32
	Motor Voltage Negative Sequence	Input Register	6186	Float32
	Voltage Imbalance Percent	Input Register	6188	Float32
	Motor Voltage Zero Sequence	Input Register	6190	Float32
	Motor Voltage Zero Sequence Percent	Input Register	6192	Float32
PA2 Motor Power	Motor Power Factor	Input Register	6194	Float32
	Surface Effective Power	Input Register	6196	Float32
	Surface Apparent Power	Input Register	6198	Float32
	Motor Output Power	Input Register	6200	Float32
	Motor Efficiency	Input Register	6202	Float32
	Motor-Cable Efficiency	Input Register	6204	Float32
PA2 Shaft Speed & Torque	Motor Torque Mean	Input Register	6206	Float32
	Motor Shaft Speed	Input Register	6208	Float32
	Motor Slip	Input Register	6210	Float32
	Synchronous Frequency Surface	Input Register	6212	Float32
PA2 Harmonics	Motor Current THD A	Input Register	6214	Float32
	Motor Current THD B	Input Register	6216	Float32
	Motor Current THD C	Input Register	6218	Float32
	Motor Current THD Percent A	Input Register	6220	Float32
	Motor Current THD Percent B	Input Register	6222	Float32
	Motor Current THD Percent C	Input Register	6224	Float32
	Motor Voltage THD AB	Input Register	6226	Float32

Group	PA2 Application Tags	Function Type	Modbus Register	Data Type
	Motor Voltage THD BC	Input Register	6228	Float32
	Motor Voltage THD CA	Input Register	6230	Float32
	Motor Voltage THD Percent AB	Input Register	6232	Float32
	Motor Voltage THD Percent BC	Input Register	6234	Float32
	Motor Voltage THD Percent CA	Input Register	6236	Float32
	Motor Current THD Max	Input Register	6238	Float32
	System Current THD Max	Input Register	6240	Float32
	Motor Voltage THD Max	Input Register	6242	Float32
	System Voltage THD Max	Input Register	6244	Float32
PA2 Phasors	Motor Phase Differential VaVa	Input Register	6246	Float32
	Motor Phase Differential VbVa	Input Register	6248	Float32
	Motor Phase Differential VcVa	Input Register	6250	Float32
	Motor Phase Differential IaVa	Input Register	6252	Float32
	Motor Phase Differential IbVa	Input Register	6254	Float32
	Motor Phase Differential IcVa	Input Register	6256	Float32

*This page is intentionally blank.*

# Appendix C: Wiring Diagrams

**Note** Select drawings are provided here for quick reference. A full set of drawings is provided with each PA2 system shipped.

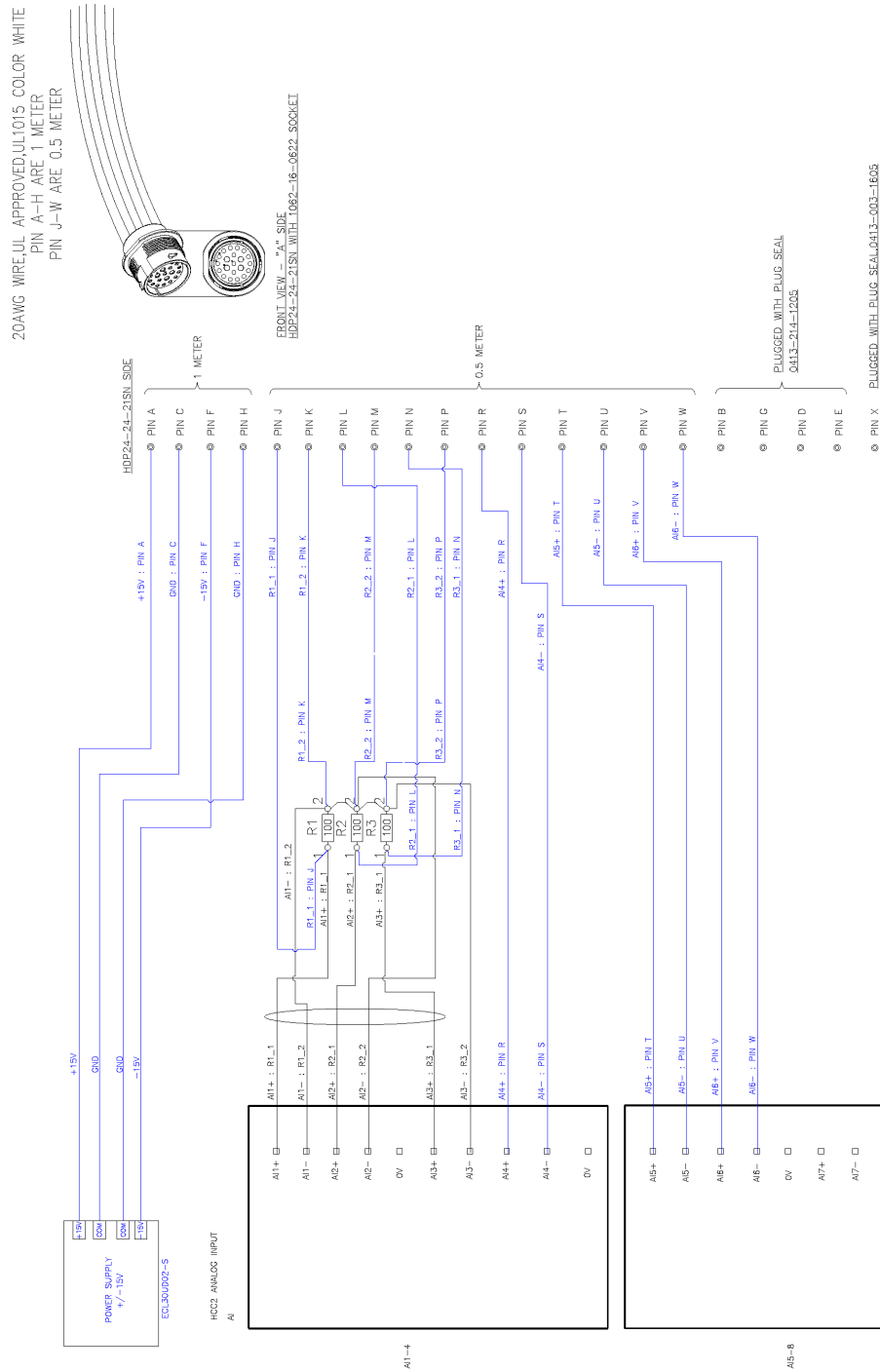
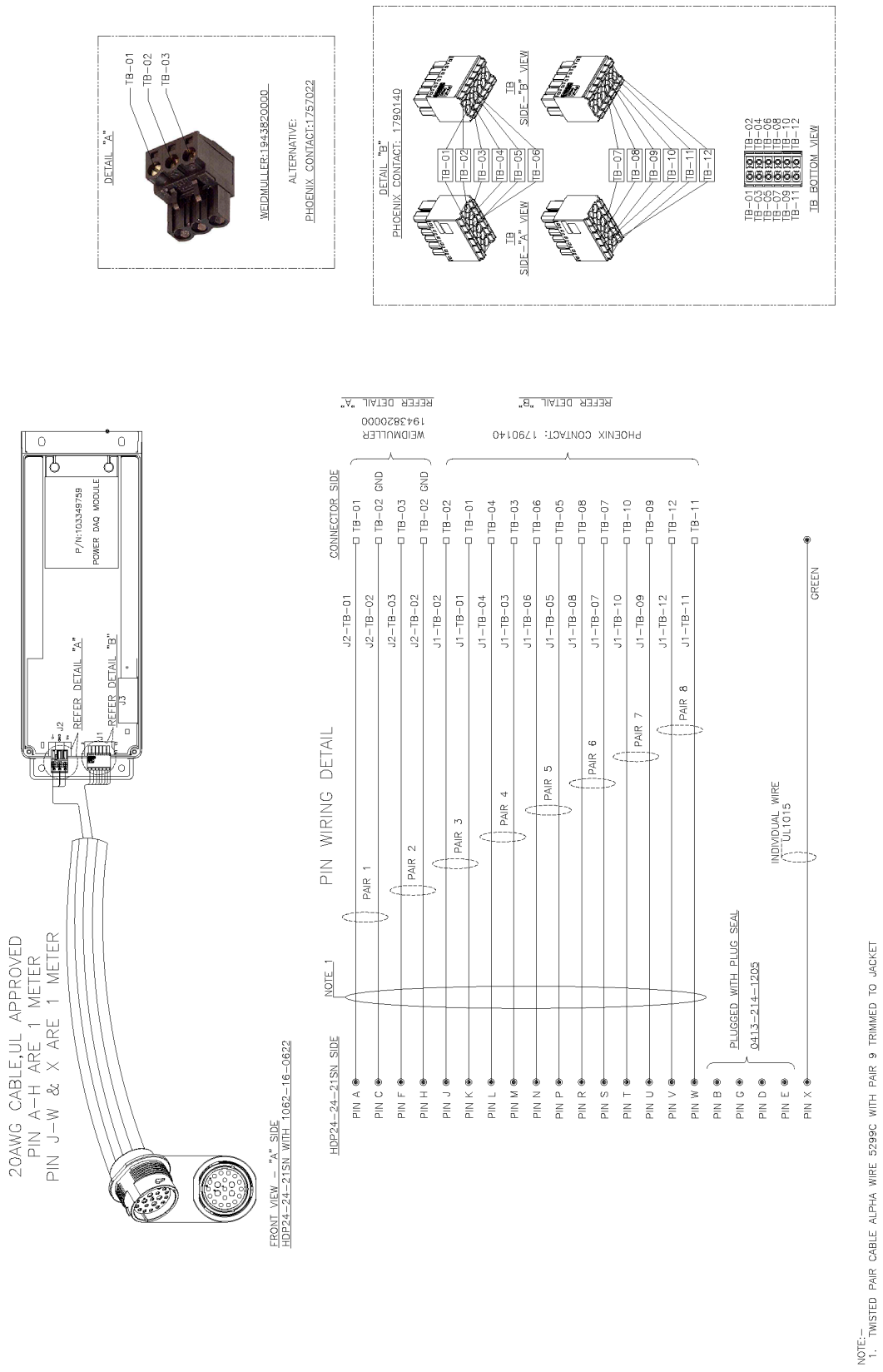
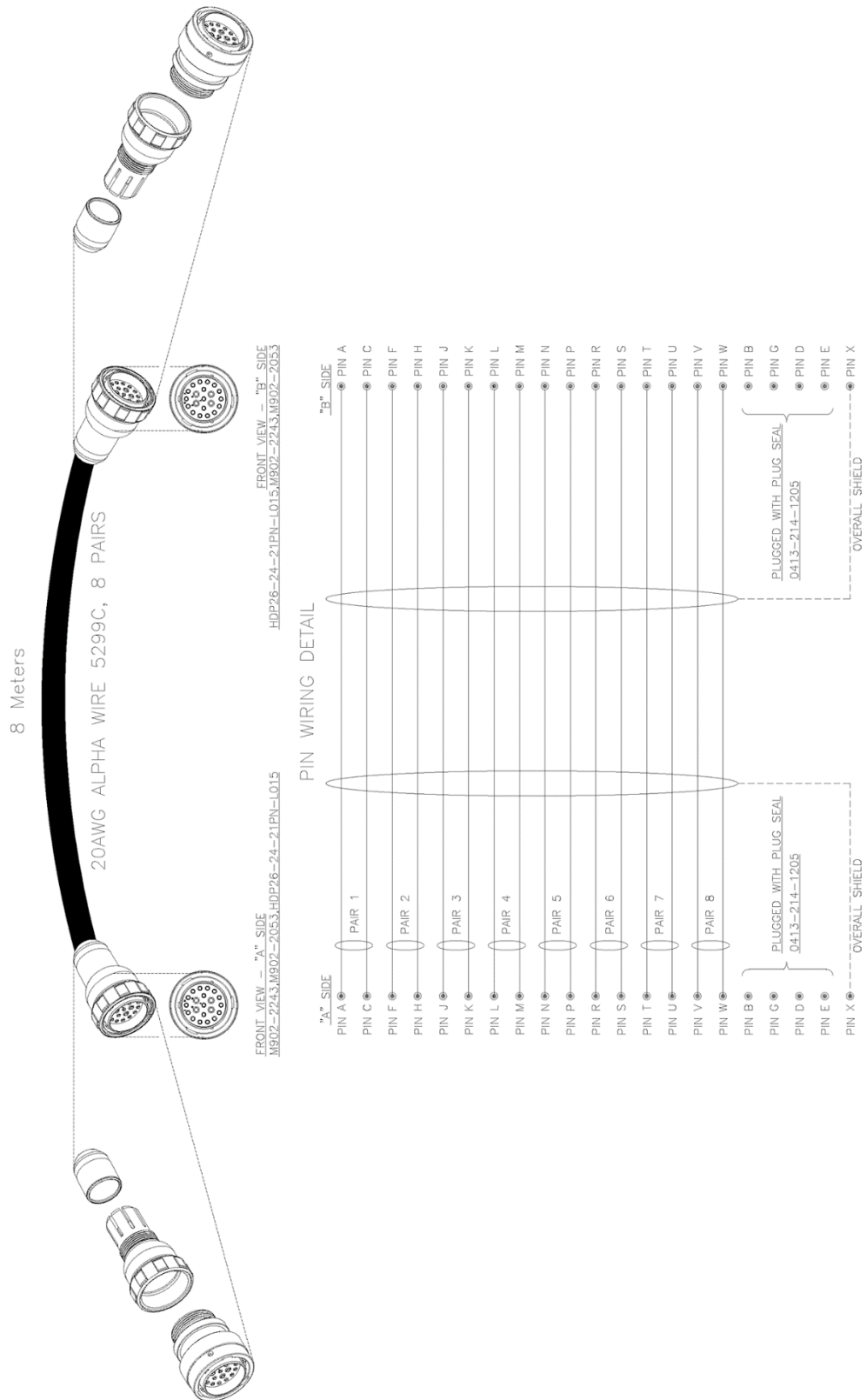

Figure C.1—PowerDAQ signal wiring



NOTE:-  
 1. TWISTED PAIR CABLE ALPHA WIRE 5299C WITH PAIR 9 TRIMMED TO JACKET

Figure C.2—Pinout detail for PowerDAQ Cable (Part No. 9A-D183262)



**Figure C.3— Pinout detail for cable connecting HCC2 and transformer cabinet quick-connect fittings. Available in 8m and 20m lengths**

*This page is intentionally blank.*

# Appendix D: Mechanical Drawings

Note Select drawings are provided here for quick reference. A full set of drawings is provided with each PA2 system shipped.

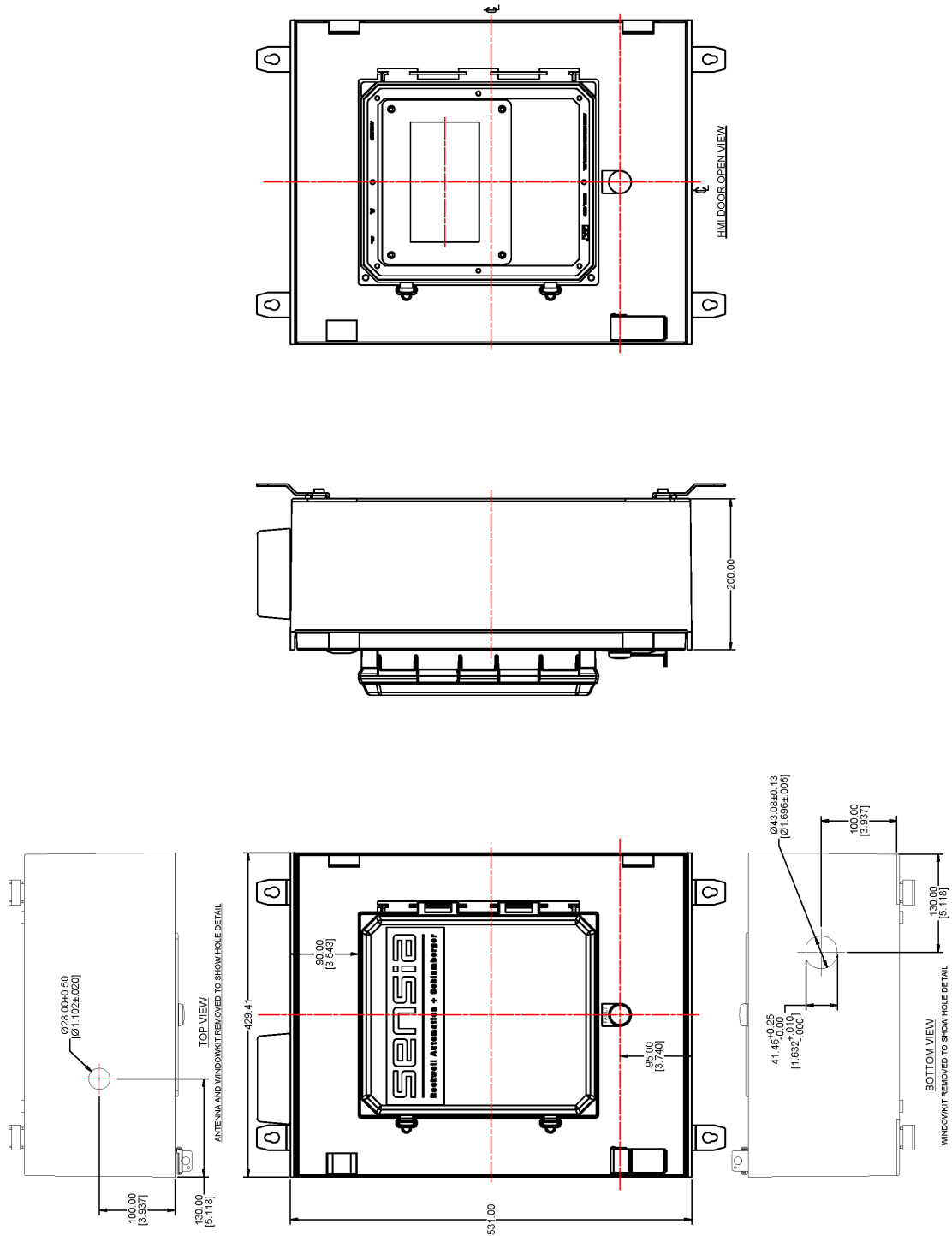
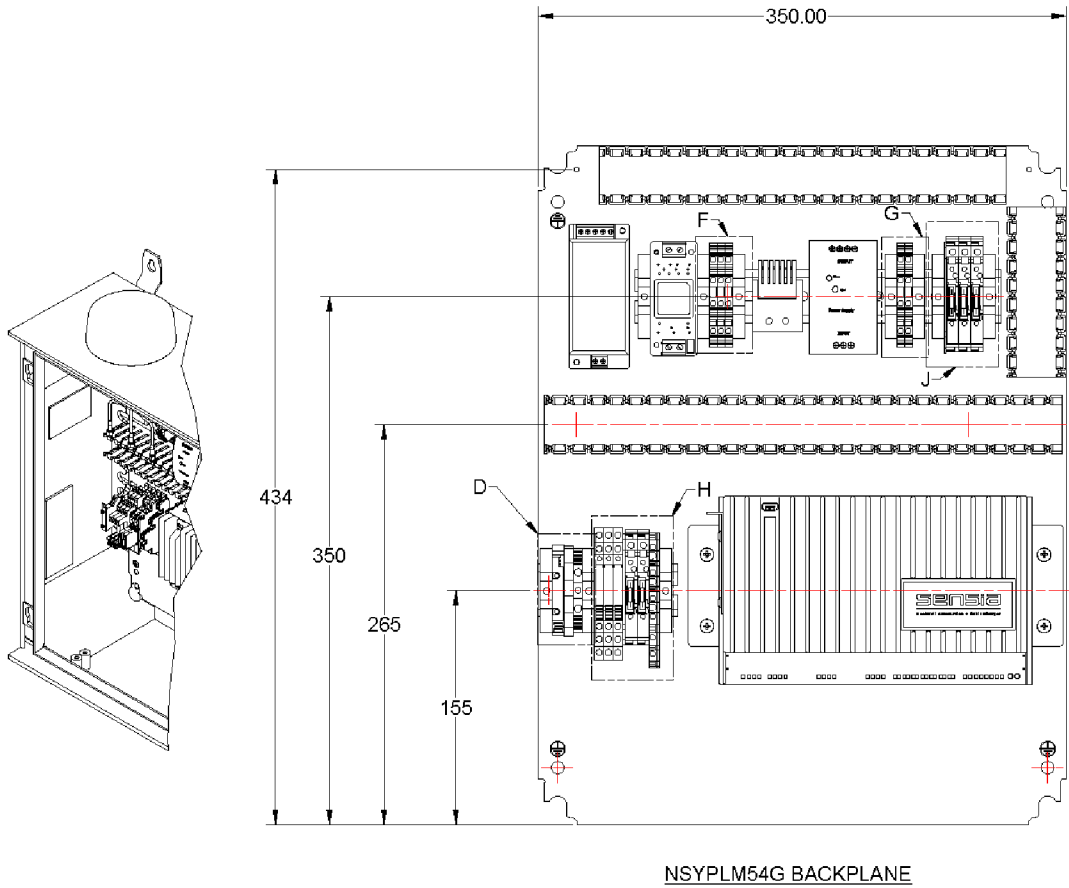

Figure D.1—HCC2 controller cabinet dimensions



NSYPLM54G BACKPLANE

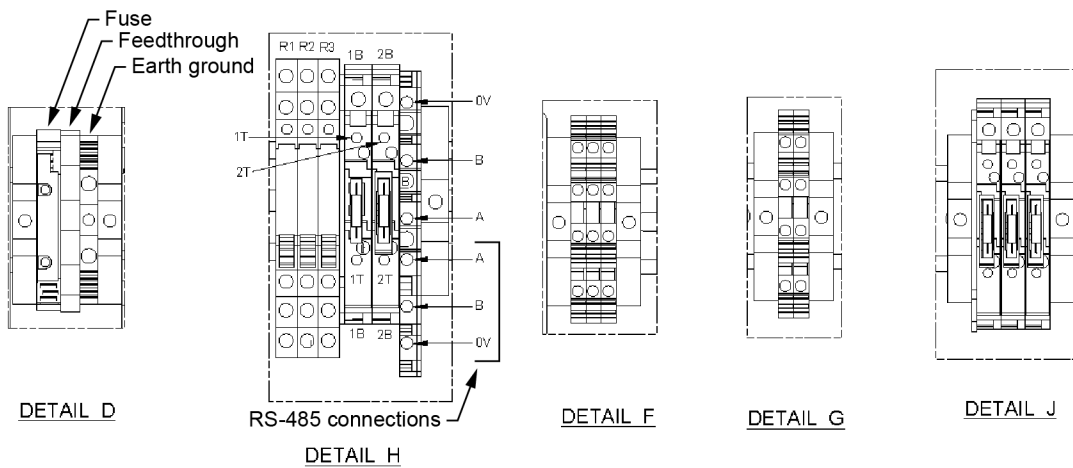

Figure D.2—HCC2 controller backplane layout

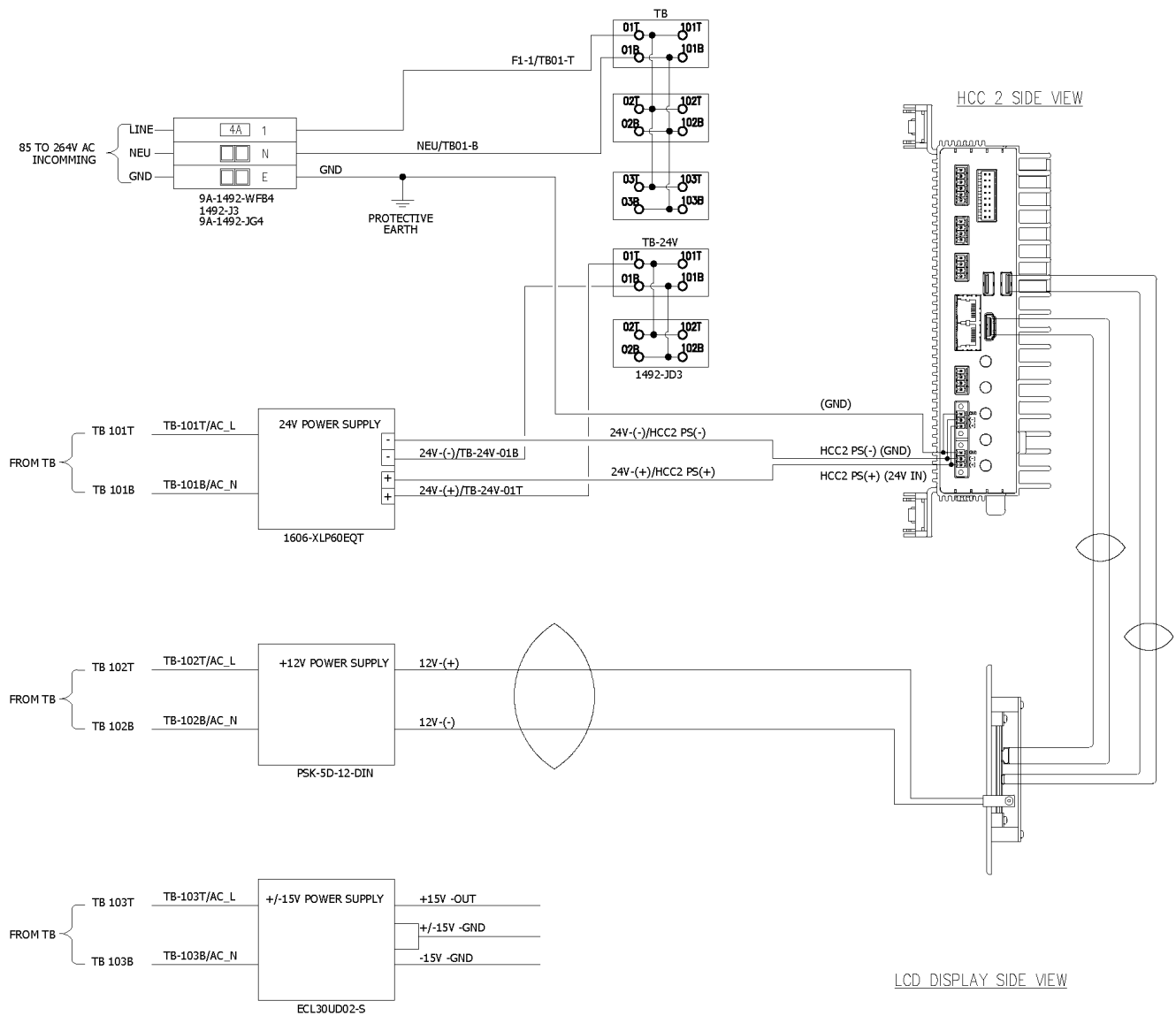

Figure D.3—HCC2 power and display wiring details

*This page is intentionally blank.*

## Appendix E: Tag Definitions (Monitoring and Charts)

Displayable Name	Type	Unit	Min Range	Max Range	Default Value
Raw Voltage Instantaneous AE	float	V	-5000.00	5000.00	0
Raw Voltage Instantaneous BE	float	V	-5000.00	5000.00	0
Raw Voltage Instantaneous CE	float	V	-5000.00	5000.00	0
Raw Current Instantaneous A	float	Amps	-300.00	300.00	0
Raw Current Instantaneous B	float	Amps	-300.00	300.00	0
Raw Current Instantaneous C	float	Amps	-300.00	300.00	0
Raw Current RMS A	float	Amps	0.00	300.00	0
Raw Current RMS B	float	Amps	0.00	300.00	0
Raw Current RMS C	float	Amps	0.00	300.00	0
Motor Current RMS A	float	Amps	0.00	300.00	0
Motor Current RMS B	float	Amps	0.00	300.00	0
Motor Current RMS C	float	Amps	0.00	300.00	0
Motor Current Pk-Pk A	float	Amps	0.00	850.00	0
Motor Current Pk-Pk B	float	Amps	0.00	850.00	0
Motor Current Pk-Pk C	float	Amps	0.00	850.00	0
Motor Current Offset A	float	Amps	0.00	10.00	0
Motor Current Offset B	float	Amps	0.00	10.00	0
Motor Current Offset C	float	Amps	0.00	10.00	0
Motor Current Calibrated RMS Zero	float	Amps	0.00	5.00	0
Motor Current Positive Sequence	float	Amps	0.00	430.00	0
Motor Current Negative Sequence	float	Amps	0.00	30.00	0
Motor Current Negative Sequence Percentage	float	%	0.00	7.00	0
Motor Current Zero Sequence	float	Amps	0.00	5.00	0
Motor Current Zero Sequence Percentage	float	%	0.00	1.50	0
Motor Current Sensor Failure Flag	bool		0.00	1	0
Motor Voltage RMS AG	float	V	0.00	5000.00	0
Motor Voltage RMS BG	float	V	0.00	5000.00	0
Motor Voltage RMS CG	float	V	0.00	5000.00	0
Motor Voltage RMS AB	float	V	0.00	5000.00	0
Motor Voltage RMS BC	float	V	0.00	5000.00	0
Motor Voltage RMS CA	float	V	0.00	5000.00	0
Motor Voltage Pk-Pk AG	float	V	0.00	14142.00	0
Motor Voltage Pk-Pk BG	float	V	0.00	14142.00	0

Displayable Name	Type	Unit	Min Range	Max Range	Default Value
Motor Voltage Pk-Pk CG	float	V	0.00	14142.00	0
Motor Voltage Pk-Pk AB	float	V	0.00	14142.00	0
Motor Voltage Pk-Pk BC	float	V	0.00	14142.00	0
Motor Voltage Pk-Pk CA	float	V	0.00	14142.00	0
Motor Voltage RMS AN	float	V	0.00	5000.00	0
Motor Voltage RMS BN	float	V	0.00	5000.00	0
Motor Voltage RMS CN	float	V	0.00	5000.00	0
Motor Voltage Pk-Pk AN	float	V	0.00	14142.00	0
Motor Voltage Pk-Pk BN	float	V	0.00	14142.00	0
Motor Voltage Pk-Pk CN	float	V	0.00	14142.00	0
Motor Voltage Offset AG	float	V	0.00	50.00	0
Motor Voltage Offset BG	float	V	0.00	50.00	0
Motor Voltage Offset CG	float	V	0.00	50.00	0
Motor Voltage Offset AB	float	V	0.00	50.00	0
Motor Voltage Offset BC	float	V	0.00	50.00	0
Motor Voltage Offset CA	float	V	0.00	50.00	0
Motor Voltage Positive Sequence	float	V	0.00	7071.00	0
Motor Voltage Negative Sequence	float	V	0.00	250.00	0
Voltage Imbalance %	float	V	0.00	3.50	0
Motor Voltage Zero Sequence	float	%	0.00	200.00	0
Motor Voltage Zero Sequence pct	float	%	0.00	2.80	0
Motor Voltage Sensor Failure Flag	bool	logic 0/1	0	1	0
Motor Power Factor	int	1	0	1	0
Surface Effective Power	float	W	0.00	1000000.00	0
Surface Apparent Power	float	VA	0.00	1400000.00	0
Motor Torque Mean	float	Nm	0.00	2600.00	0
Motor Shaft Speed	float	Hz	0.00	80.00	0
Motor Slip	float	%	0.00	11.00	0
Motor Output Power	float	W	0.00	800000.00	0
Motor Efficiency	int	1	0.00E+00	9.50E-01	0
Motor-Cable System Efficiency	int	1	0.00E+00	7.50E-01	0
Motor Current THD a	float	dB	-40.00	-6.00	-40
Motor Current THD b	float	dB	-40.00	-6.00	-40
Motor Current THD c	float	dB	-40.00	-6.00	-40
Motor Current THD pct a	float	%	1.00	50.00	0

Displayable Name	Type	Unit	Min Range	Max Range	Default Value
Motor Current THD pct b	float	%	1.00	50.00	0
Motor Current THD pct c	float	%	1.00	50.00	0
Motor Voltage THD ab	float	dB	-40.00	-6.00	-40
Motor Voltage THD bc	float	dB	-40.00	-6.00	-40
Motor Voltage THD ca	float	dB	-40.00	-6.00	-40
Motor Voltage THD pct ab	float	%	1.00	50.00	1
Motor Voltage THD pct bc	float	%	1.00	50.00	1
Motor Voltage THD pct ca	float	%	1.00	50.00	1
Motor Current THD max	float	dB	-40.00	-6.00	-40
System Current Max. THD	float	%	1.00	50.00	1
Motor Voltage THD max	float	dB	-40.00	-6.00	-40
System Voltage Max. THD	float	%	1.00	50.00	1
Motor Phase Differential VaVa	float	deg	0.00	360.00	0
Motor Phase Differential VbVa	float	deg	0.00	360.00	0
Motor Phase Differential VcVa	float	deg	0.00	360.00	0
Motor Phase Differential LaVa	float	deg	0.00	360.00	0
Motor Phase Differential LbVa	float	deg	0.00	360.00	0
Motor Phase Differential LcVa	float	deg	0.00	360.00	0
Motor Shaft Stability Indicator Bin	int	Unitless	0.00	260	0
Motor Shaft Stability Indicator Frequency	float	Hz	0.00	40.00	0
Motor Shaft Stability Indicator Magnitude	float	dB	0.00	40.00	0
Motor Current Spectrum BIN	Int	Unitless	0	525	0
Motor Power Spectrum BIN	Int	Unitless	0	525	0
Motor Current Spectrum Frequency	Float	Hz	0.00	80.00	0.00
Motor Power Spectrum Frequency	Float	Hz	0.00	80.00	0.00
Motor Current Spectrum Magnitude	Float	dB	0.00	80.00	0.00
Motor Power Spectrum Magnitude	Float	dB	0.00	80.00	0.00

*This page is intentionally blank.*

## Appendix F: Parts, Spares, Tools, and Supplies

**Table F.1: Controller & Terminal Block Plugs**

Part Number	Description
50365260-2004	QRATE HCC2 Base Model Gen 02 Assembly, App Enablement with INSTRUCT Power Analyzer 2.0 Controller Application
50369741-2004	QRATE HCC2 Wireless Model Gen 02 Assembly, App Enablement with INSTRUCT Power Analyzer 2.0 Controller Application
50372169	HCC2 CPU Board Communication Terminal Block Plug, 16-Position, 8x2
50376904	HCC2 IO Board Terminal Block Plug Kit
50386128	Antenna, Cellular

**Table F.2: Fuses**

Part Number	Description
9A-1492-WFB4	Terminal Fuse Block, 15A, 300V
9A-101155848	Fast Acting Ceramic Fuse, 4A, 250V

**Table F.3: HMI & Cables**

Part Number	Description
77027849	7-Inch Touch LCD Screen, 800x480RGB
77027850	3-Foot Double Shielded HDMI-A Male to Male Cable
77027851	1-Meter Shielded USB 2.0 Type A Male to Micro B Male Cable
77027855	3-Foot Plug to Wire Leads LCD Power Cable

**Table F.4: PowerDAQ & Cables**

Part Number	Description
50392120	PowerDAQ Interface Module Assembly
103619634	9-Position Female Socket Terminal Block Plug
101754954	12-Position, 2x6, Female Socket Terminal Block Plug
100367410	3-Position Female Socket Terminal Block Plug
50385215	PowerDAQ Cable Assembly, 1m Length for HCC2 Cabinet
9A-D183261	PowerDAQ Cable Assembly, 8m Length for Connecting HCC2 and Transformer Cabinets
9A-D183262	PowerDAQ Cable Assembly, 1m Length for High Voltage Transformer Cabinet
50394190	PowerDAQ Cable Assembly, 20m Length for Connecting HCC2 and Transformer Cabinets
50377128	PowerDAQ Resistor Module Assembly

**Table F.5: Current Sensors (CT)**

<b>Part Number</b>	<b>Description</b>
50392156	Current Sensor, Closed Loop 500A, 1-Channel
50392825	PowerDAQ Current Sensor Cable, 1m Length

**Table F.6: Enclosure**

<b>Part Number</b>	<b>Description</b>
9A-NSYPLM54G	Fiberglass/ Polyester Enclosure with Gray Cover, 530x430x200mm
50390835	HMI Cover Kit for Enclosure with Snap Latch, 12x10x2-inch
50390595	HCC2 HMI Kit with Accessories

**Table F.7: Power Supply**

<b>Part Number</b>	<b>Description</b>
50386401	24VDC, 60W, AC/DC Power Supply
77027871	+/-15VDC, 30W, AC/DC Power Supply
77027852	12VDC, 5W, AC/DC Power Supply

Scan a QR for

Technical  
Support



Customer  
Care



[sensiaglobal.com](https://sensiaglobal.com)

1-866 7 SENSIA (+1-866-773-6742)

[info@sensiaglobal.com](mailto:info@sensiaglobal.com)

Add intelligent action to your oil & gas solutions

© 2024 SENSIA. All rights reserved.

